



Stormwater Management

THE INFILTRATION RANGE



INFILTRATION MODULES INFILTRATION FILTERS
RETENTION CISTERNS SHAFTS AND ACCESSORIES



Production site in Dachstein (France)



Production site in Teningen (Germany) near Freiburg

GRAF – Setting standards in quality

For 50 years, Otto Graf GmbH has been offering high-class plastic products to its customers. In 1974, GRAF developed its first pioneering range of rainwater harvesting products. Today we are market leader in numerous countries for Rainwater Harvesting Systems.

High Quality Manufacturing

Graf is investing continuously in the expansion of the headquarters in Teningen near Freiburg (Breisgau). The facility has now an approximate area of 155.000m² and is one of the most modern production facilities for plastic products in the world.

Our choice of Germany for the new production site was easy. On the one hand, we feel an obligation to the site because of our history. On the other, we would like to offer our customers products of the highest quality.

Quality is at the forefront

To ensure consistent high product quality, you need optimised production processes and outstanding quality management. Every individual tank at the new production site in Teningen is checked for dimensional accuracy, wall thickness and weight.

All production parameters, e.g. material composition, machine settings and the staff involved in the production process, are documented for each individual product.

Our goal: your satisfaction

More than 100,000 satisfied customers already benefit from the advantages of GRAF rainwater harvesting systems.



Manufacturing certified according to ISO 9001

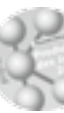
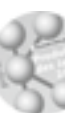
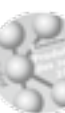



High Quality Manufacturing

Our products have to satisfy a huge number of different requirements, which is why GRAF is an expert in all the common procedures for manufacturing plastic products and has access to the optimum manufacturing process for every product.

Ecological products from the technology leader

GRAF uses state-of-the-art production facilities. This is the only way to guarantee superlative quality at attractive prices. GRAF broke new ground by using injection embossing to make the Carat underground tank. To manufacture this tank, the company developed and constructed the world's largest injection moulding machine.

Durable and 100% recyclable

Right from the stage of developing its products, GRAF attaches great importance to sustainable product design.

Long product lives ensure that fewer resources are used and the environmental impact is minimised. All products manufactured by GRAF are 100% recyclable.

Some products are also made from recycled materials – yet another boost to the environmental credentials of the GRAF product range. This means that not only do GRAF products protect the environment during use but their manufacturing process is also ecologically sound.

Sustainable production processes

While GRAF products help protect the environment, they are also manufac-

ured in an environmentally-sound way. For example, the injection moulding process consumes up to **85% less energy** than normal.

The heat generated during manufacturing is processed by a modern heat recovery system and is used to heat the production and logistics building.



World's biggest injection moulding machine



Blow moulding process



Rotational moulding

Internationally proven: GRAF infiltration technology



Industrial building, Tumeltsham (AT)



City park, Barcelona (ES)



Car dealership, Sofia (BG)



DIY chain store, Århus (DK)



Industrial building, Warwickshire (UK)



Industrial warehouse, Raben (PL)

Content

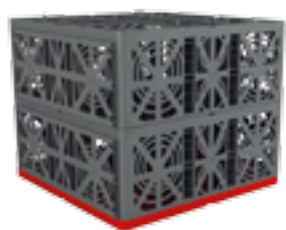

Basic information

Preserving the natural cycle
Dimensioning and planning of infiltration systems

6
8

GRAF EcoBloc Inspect flex

System overview
Advantages
Technical data
Application examples

10
12
14
16



GRAF Infiltration Tunnel / Infiltration Tunnel twin

System overview
Advantages
Technical data
Application examples

18
20
22
24



Infiltration and Multi shaft system

Infiltration and Multi shaft system
Vario 800 flex shaft system
Shaft system DN 400
Shaft system DN 600

26
28
32
34

Filter technology

Universal filter 3 external, Universal industrial filter 3 external
Infiltration filter shaft, settling filter shaft

36
37

Water detention and retention systems

Detention/Retention overview
Detention EcoBloc Inspect flex
Detention Carat S
Retention Carat S
Detention Platin
Retention Platin
Detention / Retention Carat XL
Detention / Retention Carat XXL
Detention / Infiltration Herkules

38
40
42
43
44
45
46
48
50



Accessories

Carat S
Tank dome / tank cover

52
54



www.graf-water.com

Webcode G1202

**The webcode will lead you directly
to the required information.**

- Installation instructions
- Technical drawings
- Detailed product information
- Downloads

Symbols in the catalogue

Load capacity

- Suitable for pedestrian loading
- Suitable for vehicle loading
- Lorry-bearing



Basic information/Dimensioning



Preserving the natural cycle

Surface sealing **disrupts** groundwater recharge

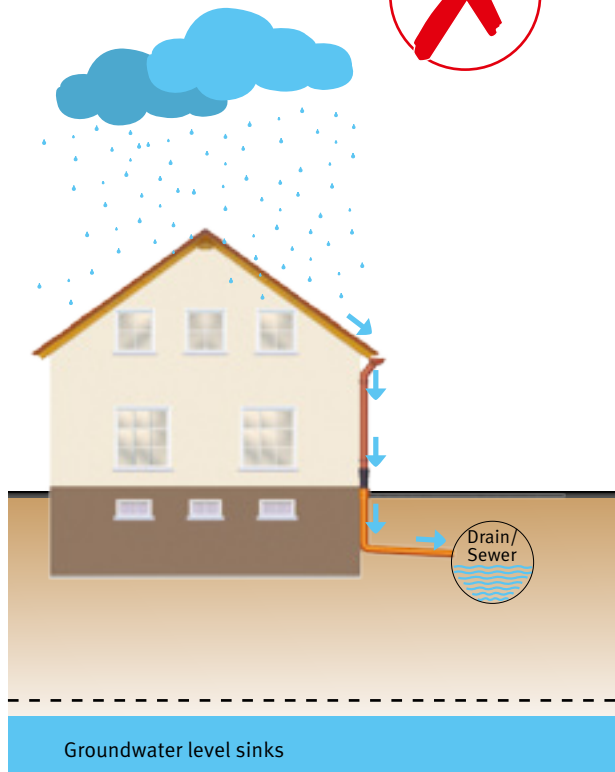

Decentralised infiltration **promotes** groundwater recharge



Legal change

With the adoption of the European Water Framework Directive (2000/60/EG), the European Parliament has set the goal of using water more sustainably and in a more environmentally friendly way. The European states will be responsible for implementing this directive.

The Water Resources Acts of most European countries will therefore be amended. The implementations can be found in many current versions – among others:

"rainwater should be drained away and irrigated locally ..., as long as this is not opposed by water legislation, other provisions of public law or water management issues."

The infiltration of rainwater locally offers considerable advantages over the previously customary draining into combined wastewater/separate sewage systems:

- Promotes groundwater recharge
- Reduces costs through lower structural costs – sewers in the separate network and wastewater lifting units can be dimensioned on a smaller scale
- Reduces the effects of surface sealing
- Minimises the hydraulic loads in the sewer system during storms
- Contributes to flooding prevention



Dimensioning and planning of infiltration systems

The following parameters are required to evaluate an infiltration system:

✓ **Determination of the catchment areas**

Connected roofs, road spaces or other sealed surfaces are evaluated with regard to the actual outflow.

✓ **Examination of the ground**

Determination of the permeability of the ground (k_f value in m/sec). This value plays a decisive role and a miscalculation can have far-reaching consequences.

✓ **Return period**

An infiltration or retention system is designed as a function of heavy rainfall events that are likely to occur over a given period of time. This period of time may vary from 5 to 100 years due to local government laws and regulations. Most of the calculations are done with 5 year rain data.

Determination of the catchment areas

The collected rainwater can be fed into ditches and drained away from roof surfaces, parking areas, paving and other sealed surfaces. Evaporation and the partially direct infiltration through the collection surfaces result in a reduction of the amount of rain that ends up in the infiltration system. This leads to differing outflow coefficients for the connected surface types (see table below). The projected surfaces are relevant for the evaluation of the amount of rain and may deviate substantially from the roof surface, particularly in the case of sloping roofs.

The effectively impermeable surface for ditch evaluation can be evaluated using the outflow coefficient and the catchment area

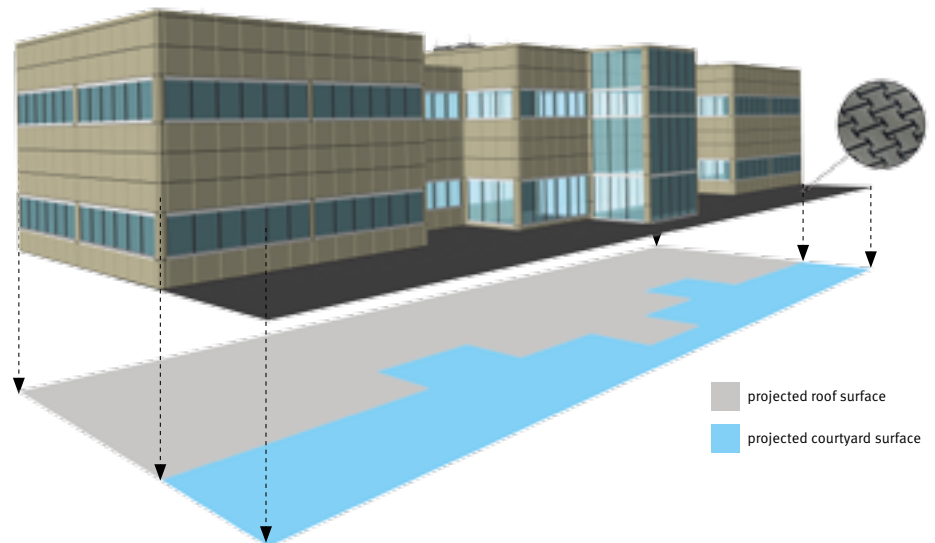

Type of surface



Roof surfaces (95%)



Concrete blocks (90%)

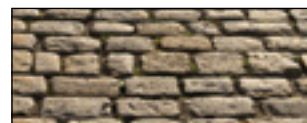

Natural/composite stone (25%)



Turf (10%)



Asphalt and concrete (90%)



Paving with sealed joints (75%)

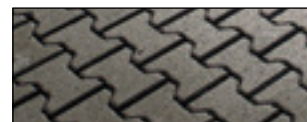

Paving with open joints (75%)



Gravel path (30%)

Examination of the ground

The ground conditions and the layer structure play an essential role in the planning of an infiltration system. The permeability of the ground and the ground/stratum water define the size and location of the ditch. A soil report should at the least include window sampling or trenching near the installation location for the evaluation of the infiltration performance. In addition, information or evaluations for the construction

of an infiltration system can be found in most soil reports. The result of the window sampling or trenching is a layer model which depicts the ground types and their distribution and thickness down to the digging depth. Infiltration systems must not be installed in layers, with permeability of $< 1 \times 10^{-6}$ m/s (clay or cohesive soil with high clay capacity). However, the ground may display a maximum permeability of $\leq 1 \times 10^{-3}$

m/s, since a minimum retention period should be achieved in the soil layers before entry of groundwater.

If the ground properties do not permit infiltration, the required k_f values can be achieved using soil replacement in special cases.

Recommended permeability values:

Soil type

Soil type	Suitable soil for infiltration		
	weak	medium	strong
Coarse gravel			—————
Fine gravel			—————
Gravel/sand mix			—————
Medium sand			—————
Fine sand			—————
Sand with a loam capacity			—————
Silt (loam)			—————
Loam with a clay capacity			—————
Clay	—————		
Permeability values	weak	medium	strong

Return period

The size of an infiltration or detention system depends on heavy rainfall events which occur over a given period of time. This period of time may vary from 5 to 100 years due to local government laws and regulations. Most of the calculations are done with 5 year rain data, see picture/table below.

Values given as an example:

D [min]	rain flow [l/sec*ha]	rain volume [l/100 m ²]
5	380.7	1142.1
10	245.6	1473.6
20	158.9	1906.8
30	123.4	2221.2
60	80.3	2890.8
120	47.8	3441.6
240	28.4	4089.6
540	15.5	5022
720	12.5	5400
1440	7.3	6307.2
2880	4.1	7084.8
4320	2.9	7516.8

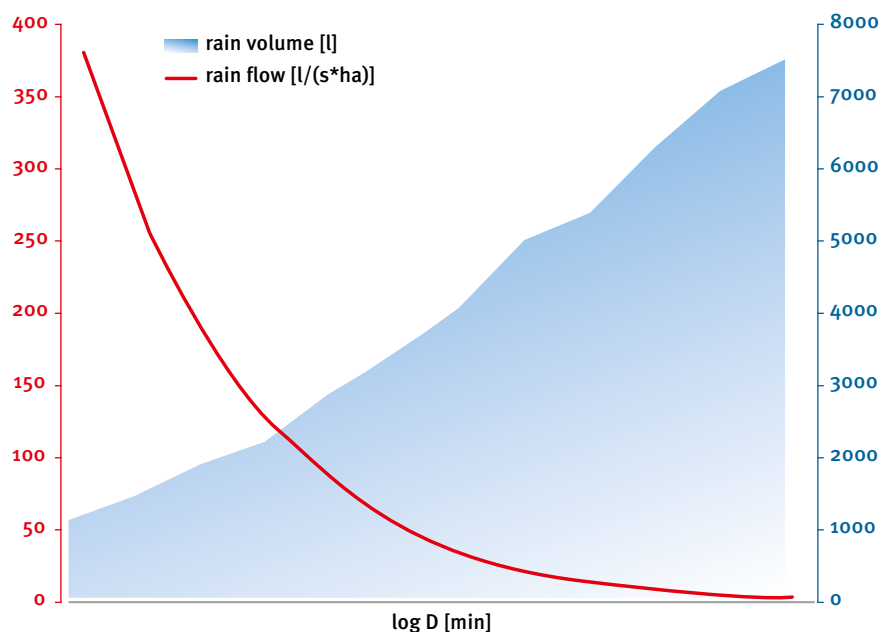

In combination with soil type, the critical value (max. value for infiltration system dimensions) could lie between 5 minutes (good soil) and 4320 minutes (clay or loam).

GRAF EcoBloc Inspect flex Stormwater management

Stormwater management ▶ EcoBloc Inspect flex



Infiltration ditch body

GRAF EcoBloc Inspect flex
Page 12–15

GRAF EcoBloc Inspect flex baseplate
Page 12–15

Infiltration ditch body accessories

Deaeration end, geotextile, and connectors
Page 14

EcoBloc Inspect flex end plates
Page 14

EcoBloc Inspect flex adapter plate
Page 14

Shaft

Vario 800 flex, type 1
Page 28–31

Vario 800 flex, type 2
Page 28–31

Vario 800 flex, base/cover set
Page 28–31

Shaft accessories

Telescopic dome shaft pedestrian loading
Page 55

Mini Maxi

Telescopic dome shaft vehicle loading max. load 3.5 t
Page 55

Telescopic dome shaft lorry bearing
Page 55

Infiltration inlet module DN 600
Page 34/35

Infiltration connecting piece DN 600
Page 34/35

Infiltration filter strainer DN 600
Page 34

Infiltration choke drain DN 100/DN 150
Page 32/34

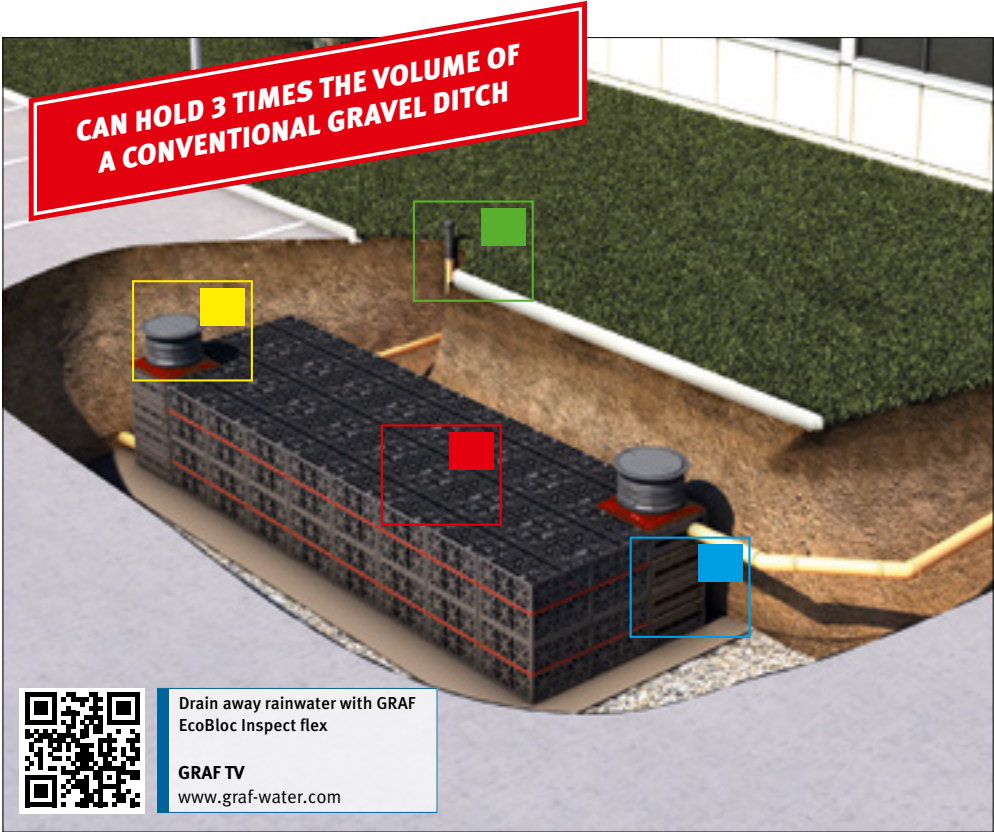

Drain away rainwater with GRAF EcoBloc Inspect flex

GRAF TV
www.graf-water.com

GRAF EcoBloc Inspect flex

The third-generation GRAF infiltration and attenuation system



Twice the volume per truck

To save space during transport, two EcoBloc Inspect flex modules are stacked one inside the other. This halves transport costs and CO₂ emissions.

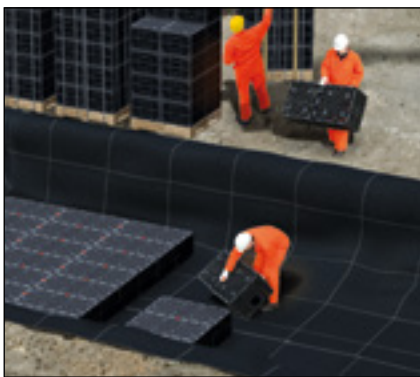
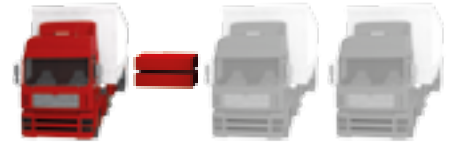

Easy to install

GRAF EcoBloc Inspect flex modules are easy to transport and install. The modular system structure requires few accessories.



Easy to inspect

The standard inspection channel allows the entire percolation system to be monitored effectively. The EcoBloc Inspect flex system allows access by commercially available inspection cameras. This has been confirmed by several independent testing authorities.

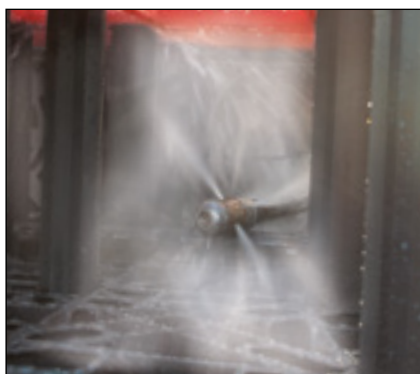

High pressure jetting possible

GRAF EcoBloc Inspect flex system can easily resist high pressure jetting.

205 l
(54.2 US gal.)

205 l
(54.2 US gal.)

25 l
(6.6 US gal.)

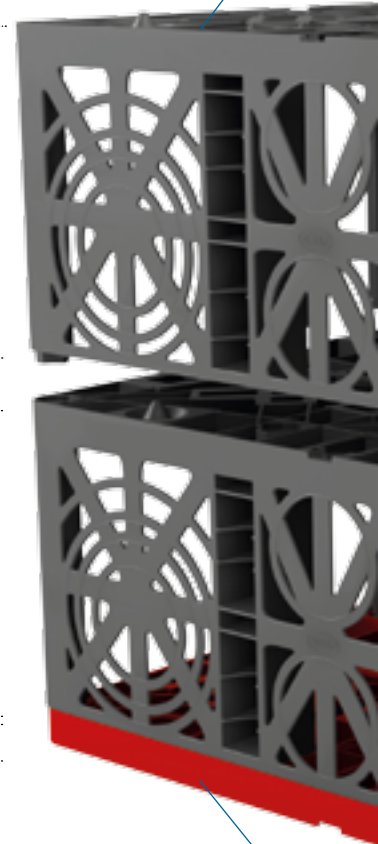

Highly flexible

Each EcoBloc Inspect flex module has a volume of 205 l (54.2 US gal.), an area of 800 x 800 x 320 mm (31.4" x 31.4" x 12.6") and a height of 320 mm (12.6"). The system size and load bearing can be adjusted individually to suit requirements of traffic and non-traffic areas.

Lorry-bearing up to 60 t

The GRAF EcoBloc Inspect flex has a heavy-duty lorry-bearing capacity of 60 tons with an 800 mm (31.4") earth covering.

Installation depth of up to 5 metres (16' 4.8")

Even under very heavy loads, GRAF EcoBloc Inspect flex system can be installed at a depth of up to 5 metres (16' 4.8"). This means that up to 14 layers are possible.

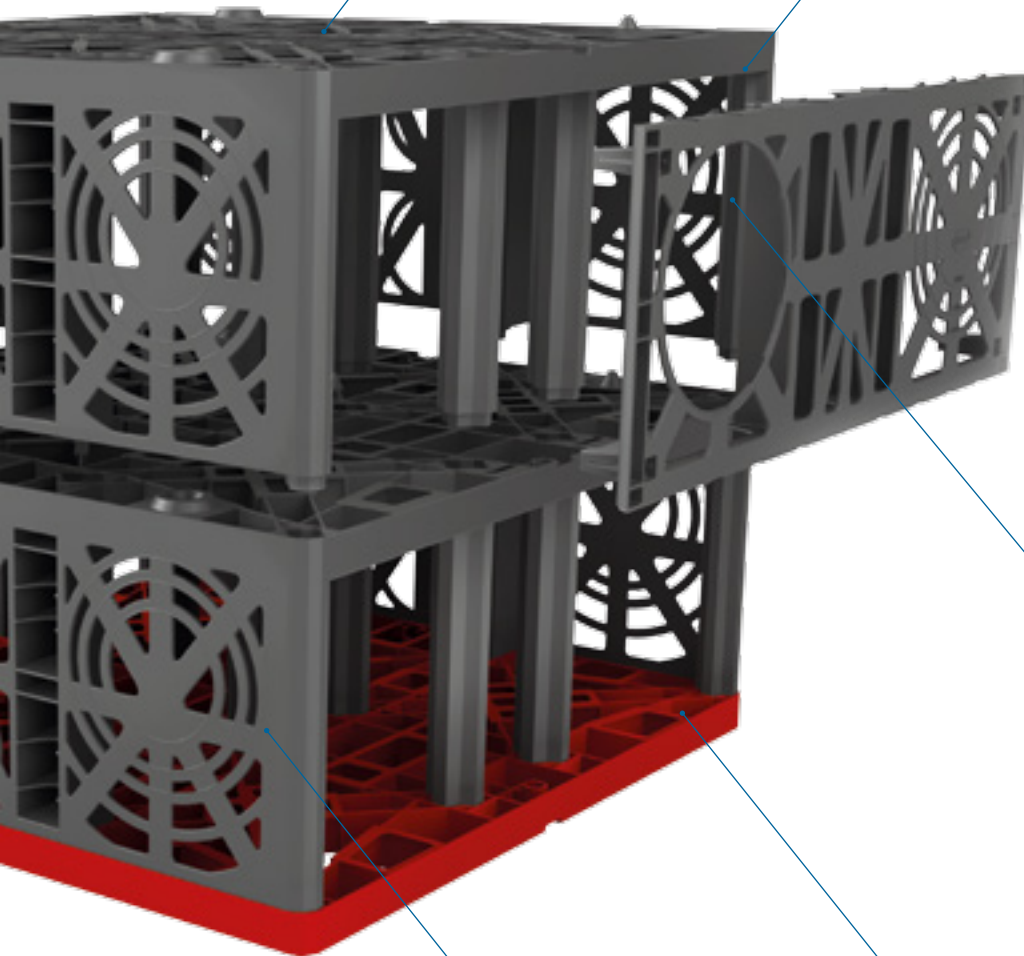

Connection up to DN 500 (20")

Large percolation volumes require large pipe cross-sections. This is not a problem for GRAF EcoBloc Inspect flex: it has DN 100 (4"), 150 (6") and 200 (8") connections on all sides. DN 100 (4") connections are positioned eccentrically at the side for complete deaeration. Larger connections of up to DN 400 (16") are available in conjunction with the Vario 800 flex, type 2. Connections of up to DN 500 (20") could be realised with GRAF adapter plates.

Designed for decades of use

A durable product design ensures sustainability. The GRAF EcoBloc Inspect flex is designed for a **service life of over 50 years**.

Universal use

For rainwater infiltration, detention, retention or rainwater harvesting

High percolation rate

The GRAF EcoBloc Inspect flex system is designed to have a high rate of percolation and barrier-free inspection.

GRAF EcoBloc Inspect flex

The third-generation GRAF infiltration and attenuation system

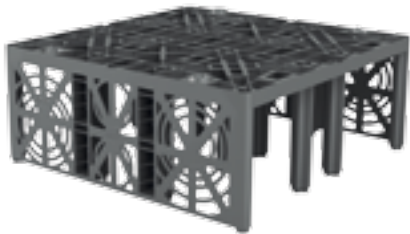

GRAF EcoBloc Inspect flex

For large storage volumes

DN 100 (4")/150 (6")/200 (8") connecting faces

Volume	Length	Width	Height	Weight	Colour	Order no.
205 l (54.2 US gal.)	800 mm (31.4")	800 mm (31.4")	320 mm (12.6")	8 kg (17.6 lbs)	grey	402005

[Webcode G4105](#)

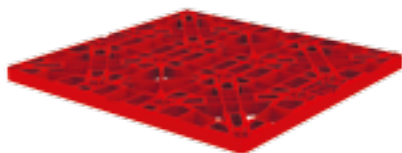

GRAF EcoBloc Inspect flex baseplate

Forms the foundation of the EcoBloc Inspect flex system

Volume	Length	Width	Height	Weight	Colour	Order no.
25 l (6.6 US gal.)	800 mm (31.4")	800 mm (31.4")	40 mm (1.6")	4 kg (8.8 lbs)	grey	402006

[Webcode G4106](#)

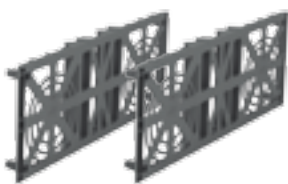

GRAF EcoBloc Inspect flex end plates

The front ends of an EcoBloc Inspect flex system are sealed with end plates

DN 100 (4")/150 (6")/200 (8") contact surfaces

Item	Colour	Order no.
EcoBloc Inspect flex end plates (Set 2 units)	grey	402002

EcoBloc Inspect flex accessories

EcoBloc Inspect flex connectors

For horizontal connection



Order no. 402010	Set 4 units
Order no. 402015	Set 10 units
Order no. 402018	Set 25 units
Order no. 402020	Set 50 units
Order no. 402025	Set 200 units

Deaeration end

DN 100 (4")

Order no. 369017



Adapter plate

Order no. 402030	DN 300 (12")
Order no. 402031	DN 400 (16")
Order no. 402032	DN 500 (20")



GRAF-Tex geotextile

For one Infiltration Tunnel

Size: 2.50 x 2.50 m (8' 2.4" x 8' 2.4")

Order no. 231006



Sold by the metre, roll width 5 m

Size: 5 m (16' 4.8")

Order no. 231002

Installation window

EcoBloc Inspect flex	Without traffic load	Vehicle	Lorry 12	Lorry 30	Lorry 40	Lorry 60
min. earth covering	250 mm (9.8")	250 mm (9.8")	500 mm (16.7")	500 mm (16.7")	500 mm (16.7")	800 mm (31.4")
max. earth covering	2750 mm (9')	2750 mm (9')	2750 mm (9')	2500 mm (8' 2.4")	2250 mm (7' 4.5")	2000 mm (6' 6.7")
max. installation depth	5000 mm (16' 4.8")	5000 mm (16' 4.8")	5000 mm (16' 4.8")	5000 mm (16' 4.8")	5000 mm (16' 4.8")	5000 mm (16' 4.8")
max. number of layers	14	14	13	13	13	13

Technical data for EcoBloc Inspect flex

Weight	8 kg (17.6 lbs)
Gross volume	205 l (54.2 US gal.)
Net volume	195 l (51.5 US gal.)

Technical data for EcoBloc Inspect flex baseplate

Weight	4 kg (8.8 lbs)
Gross volume	25 l (6.6 US gal.)
Net volume	20 l (5.2 US gal.)

Load capacity

Short-term	max. 100 kN/m ²
Long-term	max. 59 kN/m ²

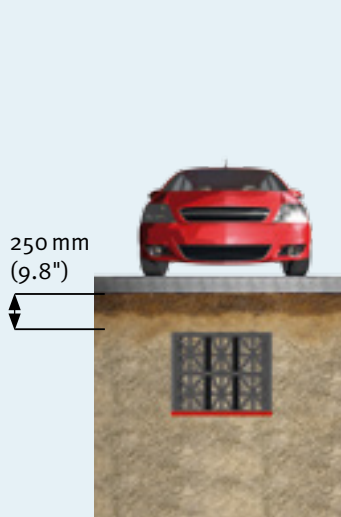

Vehicle loading

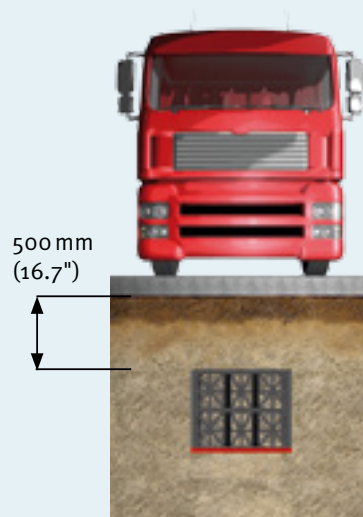

Lorry-bearing 40 t

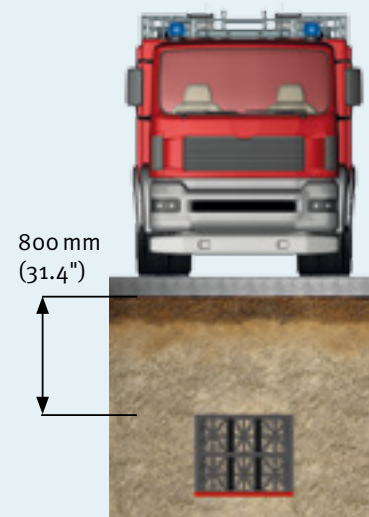

Lorry-bearing 60 t

GRAF EcoBloc Inspect flex

Areas of application

Front view

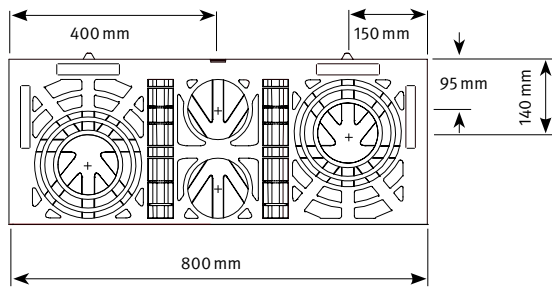

Side view

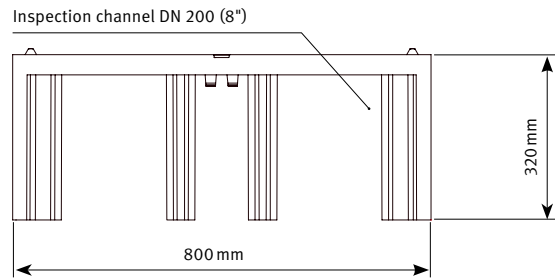

Top view

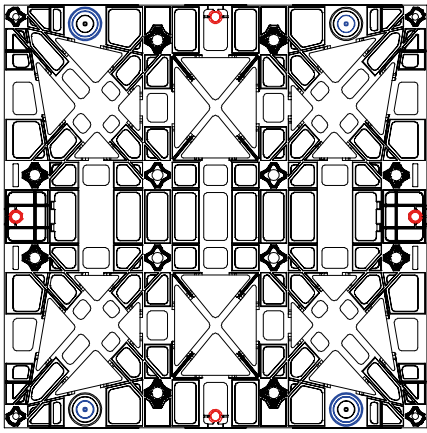

red = connector position, blue = centering



Percolating rainwater with GRAF EcoBloc Inspect flex
GRAF TV
www.graf-water.com

An EcoBloc Inspect flex system can be installed without any special tools or unreasonable effort. The video "Percolating rainwater with GRAF EcoBloc Inspect flex" on GRAF TV provides a rough overview of how an EcoBloc infiltration ditch system works and is installed.

Rainwater harvesting with GRAF EcoBloc Inspect flex

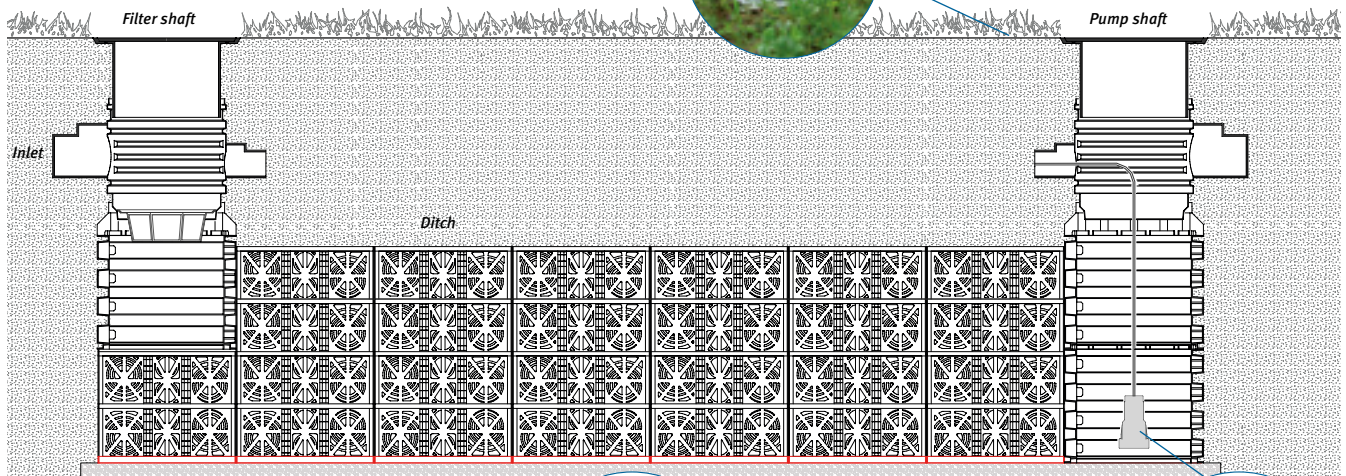

Geotextile
2 mm HDPE film
Geotextile

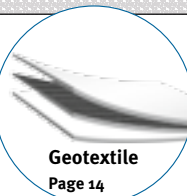

Geotextile
Page 14

Pump



Ditch infiltration with GRAF EcoBloc Inspect flex

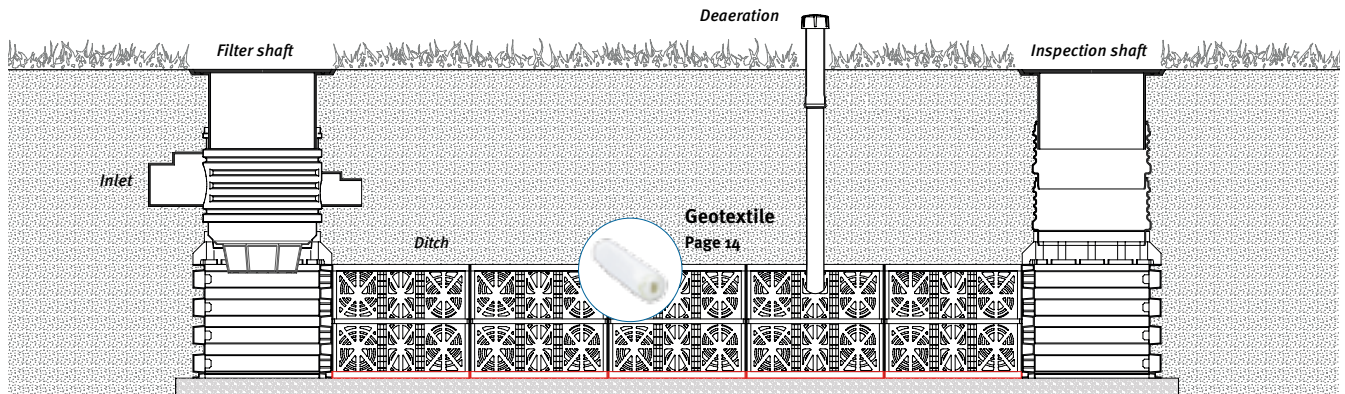

Combined rainwater harvesting and infiltration with GRAF EcoBloc Inspect flex

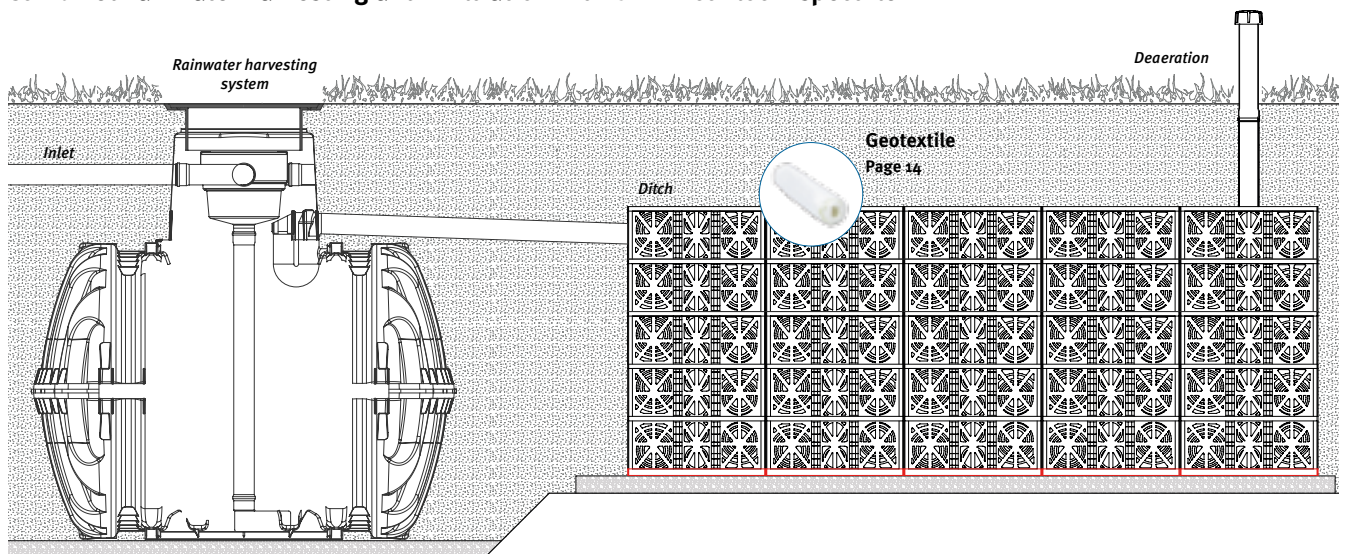

GRAF Infiltration Tunnel/twin Ditch system



Infiltration ditch body

Infiltration Tunnel
Page 20–22



Infiltration Tunnel twin
Page 20–23



Infiltration ditch body accessories

Deaeration end, geotextile, and connectors
Page 22



Infiltration Tunnel/twin end plate
Page 22



Shaft

Infiltration shaft DN 400
Page 32/33



Infiltration shaft DN 600
Page 34/35



Shaft accessories

Telescopic dome shaft pedestrian loading
Page 55



Mini Maxi

Telescopic dome shaft vehicle loading max. load 3,5 t
Page 55



Telescopic dome shaft lorry bearing
Page 55



Infiltration connecting piece DN 400
Page 32/33



Infiltration connecting piece DN 600
Page 34/35



Filter strainer DN 400/DN 600
Page 32/34

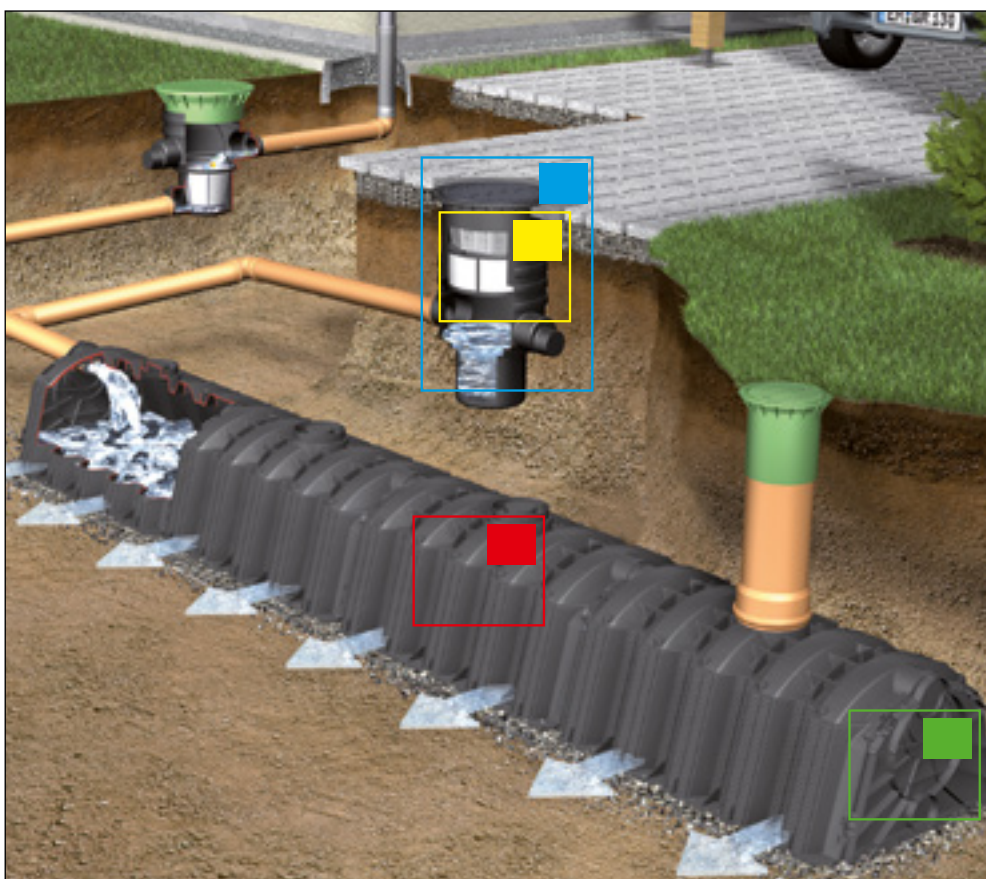

Infiltration choke drain DN 100 /DN 150
Page 32/34

GRAF Infiltration Tunnel / twin

The logistical miracle – can be laid in rows



Easy installation

The GRAF Infiltration Tunnels are laid in lines and can be flexibly adapted to specific conditions and to the individual storage volume requested. The installation of the modules is easy, quick and variable. The installation is possible without heavy equipment, as one Infiltration Tunnel only weighs 11 kilos. The tunnel modules are simply stuck together in one line and equipped with 2 end plates per line.



Infiltration Tunnel twin – Twice the volume with the same space requirement

Upon request, the Infiltration Tunnel twin 600 litres (158 US gal.) offers volume through the connection of two identical Infiltration Tunnel modules.



Up to 12,000 litres infiltration volume per pallet

Thanks to its special design, the GRAF Infiltration Tunnel can be stacked easily. Consequently, the shipment of up to 40 Infiltration Tunnels on one pallet saves considerable transport and storage costs.



- up to 500,000 litres per lorry
- 975 items per 40" HC container

300 l Volume

The compact dimensions combined with a storage coefficient of 100% result in a useful volume of 300 l (79 US gal.).

Lorry-bearing up to 60 t

In order to enable the free arrangement of surfaces above it, the Infiltration Tunnel features long-term resistance with 59 kN/m² (Infiltration Tunnel twin 35 kN/m²) and is therefore lorry-bearing.

100% storage volume

The typical shape of the Infiltration Tunnel enables complete utilisation of the available volume for the temporary storage of rainwater.

Connections up to DN 300 (12")

Large infiltration volumes require large pipe diameters. For the GRAF Infiltration Tunnel, this is not a problem: each end plate features connections in the sizes DN 100 (4"), 150 (6"), 200 (8") and 300 (12"). In addition, connections in the sizes DN 100 (4") and 200 (8") are provided on the upper surface for the connection of a ventilation system or an inspection opening.

High infiltration performance

The ditch elements are placed directly upon an even layer of gravel. The sides are then covered with geotextile and the end faces are closed using end plates. This installation and the side slats ensure a permanent high infiltration performance.

Installation depth of over 4 metres

The GRAF Infiltration Tunnel can be installed at a depth of up to 4.25 metres (13' 11"), even under heavy loads. The maximum installation depth for the Infiltration Tunnel twin is 2.5 metres (8' 2.4").

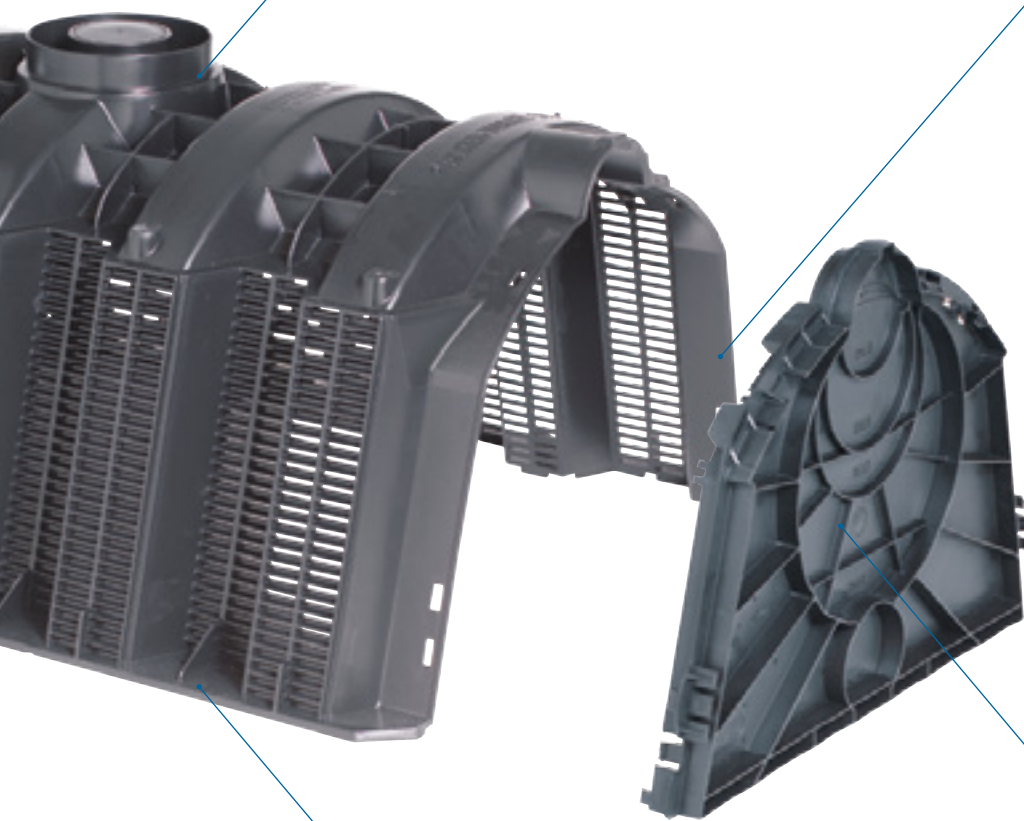

GRAF Infiltration Tunnel / GRAF Infiltration Tunnel twin



Infiltration Tunnel lorry

Volume	Length	Width	Height	Weight	Colour	Order no.
300 l (79 US gal.)	1160 mm (45.7")	800 mm (31.5")	510 mm (20")	11 kg (24.4 lbs)	black	230010

[Q Webcode G4103](#)



Infiltration Tunnel twin car

Consisting of two tunnels and 1 set of click-bolt connectors

Volume	Length	Width	Height	Weight	Colour	Order no.
600 l (158 US gal.)	1160 mm (45.7")	800 mm (31.5")	1020 mm (40")	22 kg (48.8 lbs)	black	410130

[Q Webcode G4104](#)



End plate for Infiltration Tunnel / twin

Item	Colour	Order no.
End plates (Set of 2 units)	black	231004

Inspection end
DN 200 (8")



Order no. 340527

Deaeration end
DN 100 (4")



Order no. 369017

GRAF-Tex geotextile

For one Infiltration Tunnel
Size: 2.50 x 2.50 m (8' 2.4" x 8' 2.4")



Order no. 231006

GRAF click-bolt connectors

Connector for Infiltration Tunnel twin (set of 6 for one Infiltration Tunnel twin car)



Order no. 410094

Sold by the metre, roll width 5 m

Size: 5 m (16' 4.8")

Order no. 231002

Installation window

Infiltration Tunnel	Without traffic load	Vehicle	Lorry 12	Lorry 30	Lorry 40	Lorry 60
min. earth covering	250 mm (9.8")	250 mm (9.8")	500 mm (16.7")	500 mm (16.7")	500 mm (16.7")	750 mm (29.5")
max. earth covering	3740 mm (12' 3.2")	3490 mm (11' 5.4")	3240 mm (10' 7.5")	2740 mm (10' 7.6")	2490 mm (8' 2")	1740 mm (5' 8.5")
max. installation depth	4250 mm (13' 11.3")	4000 mm (13' 1.5")	3750 mm (12' 3.6")	3250 mm (10' 8")	3000 mm (9' 10.1")	2250 mm (7' 4.6")

Infiltration Tunnel twin	Without traffic load	Vehicle	Lorry 12	Lorry 30	Lorry 40	Lorry 60
min. earth covering	250 mm (9.8")	500 mm (16.7")	-	-	-	-
max. earth covering	1480 mm (4' 10.3")	1480 mm (4' 10.3")	-	-	-	-
max. installation depth	2500 mm (8' 2.4")	2500 mm (8' 2.4")	-	-	-	-

Technical data for GRAF Infiltration Tunnel lorry / Infiltration Tunnel twin car

	Infiltration Tunnel lorry	Infiltration Tunnel twin car
Volume	300 litres (79 US gal.)	600 litres (158 US gal.)
Length	1160 mm (45.7"), 1220 mm (48") (incl. end plates)	
Width	800 mm (31.5")	
Height	510 mm (24")	1020 mm (48")
Connections	upper side: DN 100 (4"), 150 (6"), 200 (8"), 300 (12") lower side: DN 100 (4")	4 x DN 100 (4"), 2 x DN 150 (6"), 2 x DN 200 (8"), 2 x DN 300 (12")
Weight	approx. 11 kilos	
Material	100% made out of recycled polypropylene (PP)	

Load capacity Infiltration Tunnel lorry

Short-term	max. 100 kN/m ²
Long-term	max. 59 kN/m ²

Load capacity Infiltration Tunnel twin car

Short-term	max. 75 kN/m ²
Long-term	max. 35 kN/m ²

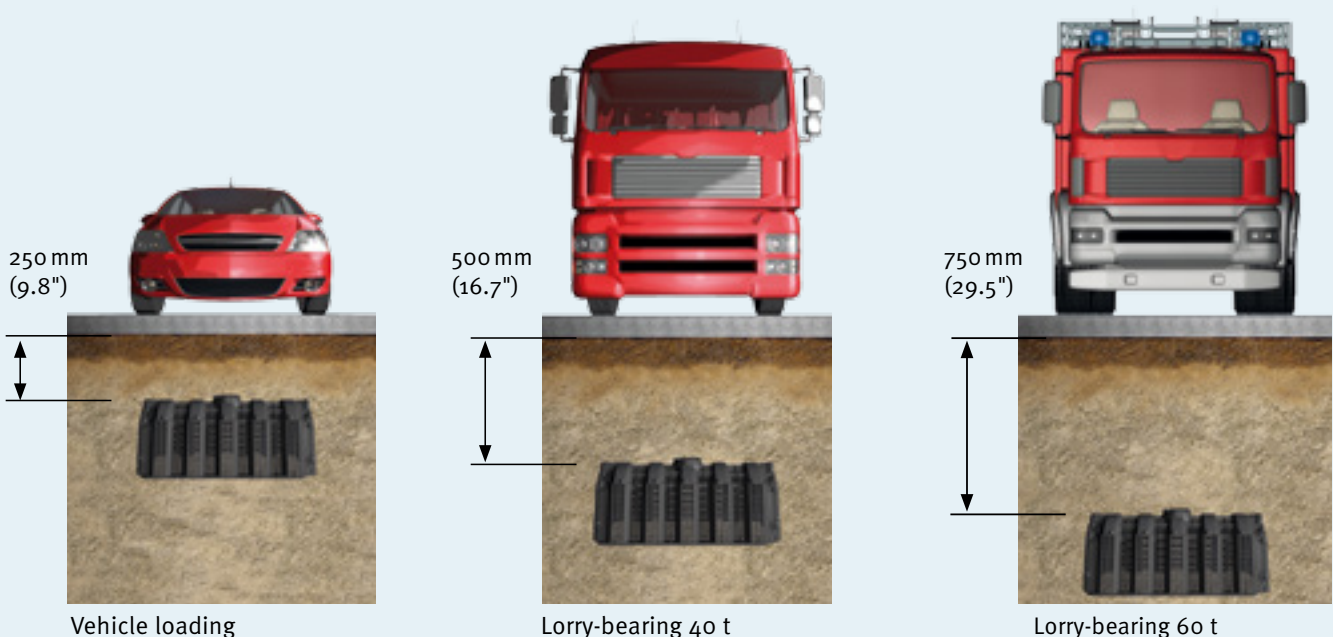

GRAF Infiltration Tunnel / twin

Areas of application

Front view

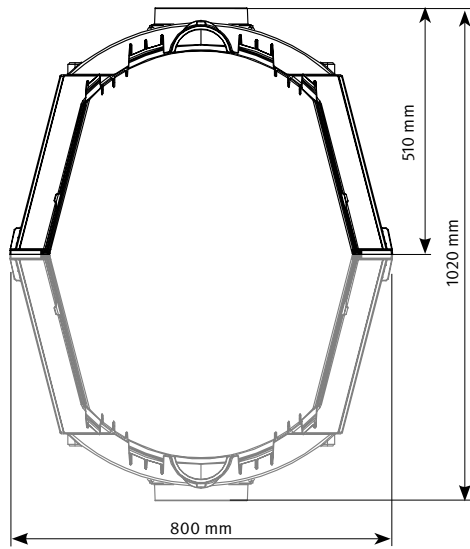

Side view

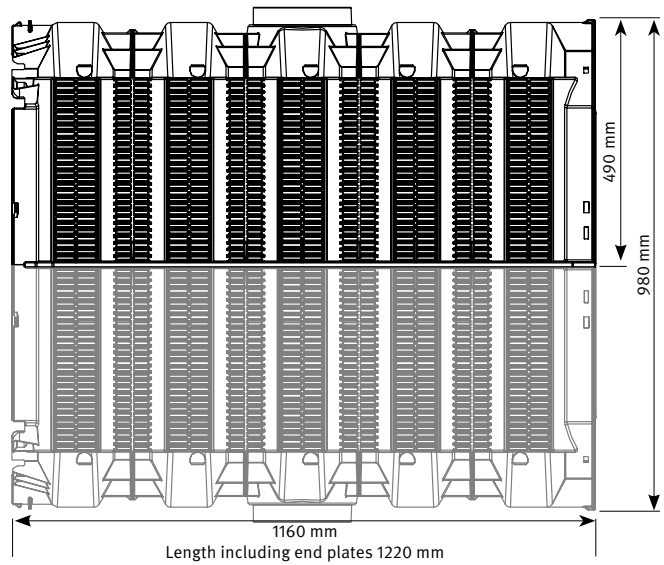

Top view

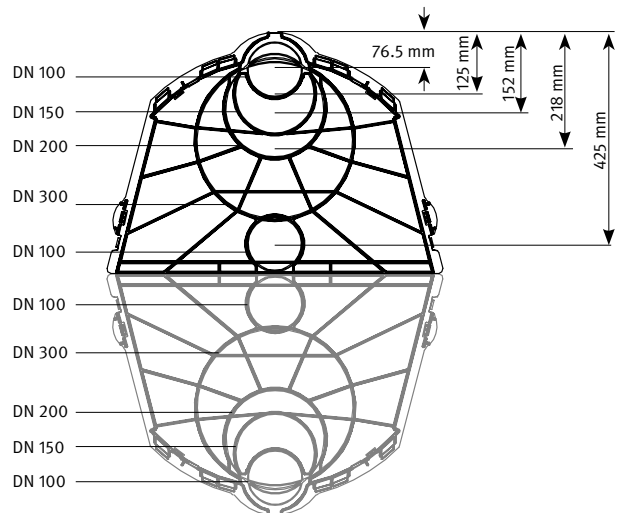
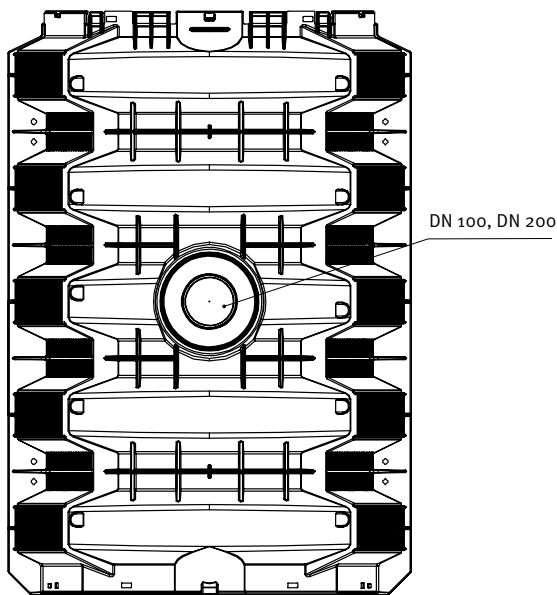

Infiltration Tunnel twin consisting of two identical Infiltration Tunnel half shells



Infiltration Tunnel

- Lorry-bearing up to 60 t
- 300 l net volume
- max. DN 300 connections



Infiltration Tunnel twin

- pedestrian and vehicle loading
- 600 l net volume
- max. DN 300 connections

Ditch infiltration with GRAF Infiltration Tunnel

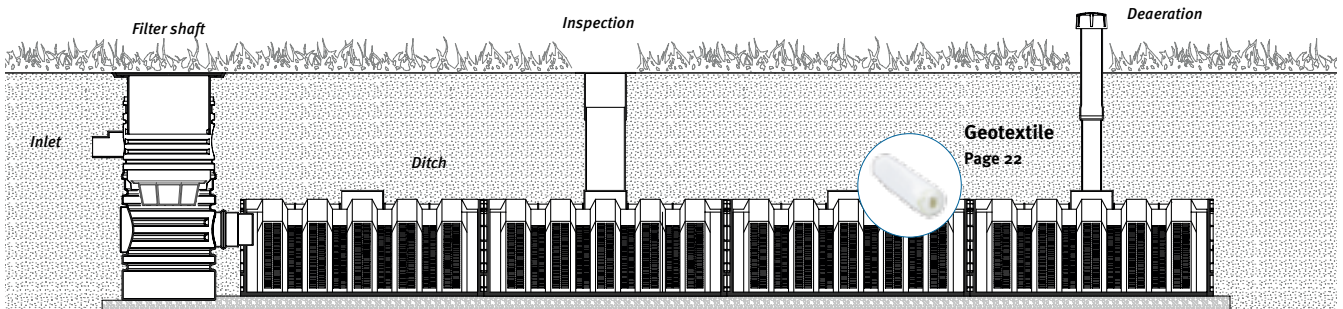

Ditch infiltration with GRAF Infiltration Tunnel twin

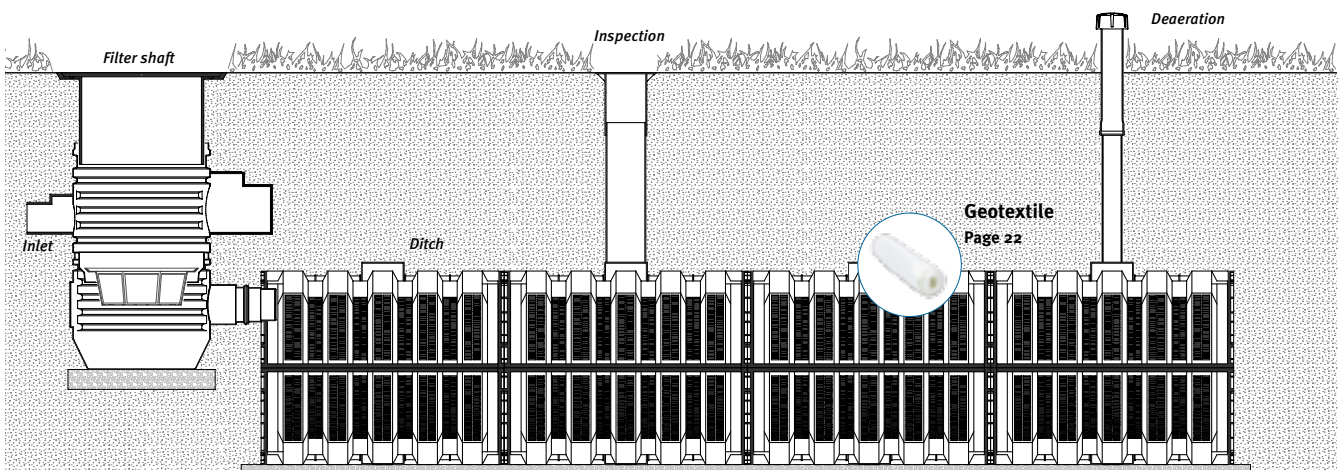

Combined rainwater harvesting and infiltration GRAF Infiltration Tunnel

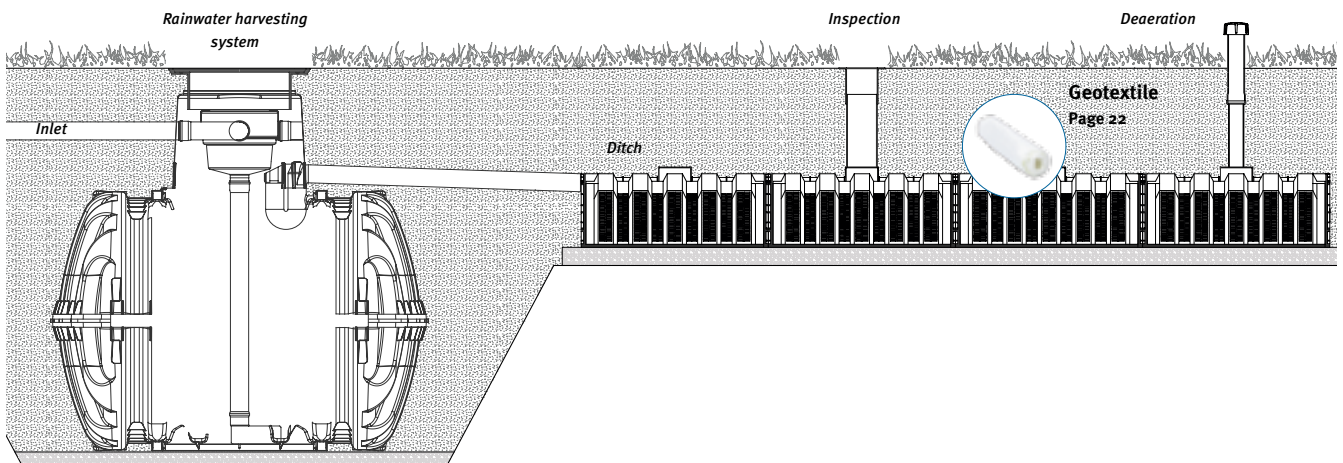

Infiltration and Multi shaft system



Filters and shafts	Vario 800 flex	Infiltration shaft system DN 400	Infiltration shaft system DN 600	Universal Industrial External	Universal Filter 3	Infiltration filter shaft	Settling filter shaft
Dimension	800 x 800 mm (31.4" x 31.4")	Ø 400 mm (15.75")	Ø 600 mm (23.62")	Ø 600 mm (23.62")	Ø 400 mm (15.75")	Ø 600 mm (23.62")	Ø 400 mm (15.75")
Loading class							
	•	•	•	•	•	•	•
	•	•	•	•	•	•	•
	•	•	•	•	○	○	○
Connection options / flow rates							
DN 100 (4")	–	5.5 l/sec.	5.5 l/sec.	–	5.5 l/sec.	5.5 l/sec.	5.5 l/sec.
DN 150 (6")	–	16 l/sec.	16 l/sec.	16 l/sec.	16 l/sec.	16 l/sec.	16 l/sec.
DN 200 (8")	29.5 l/sec.	29.5 l/sec.	29.5 l/sec.	29.5 l/sec.	–	–	–
DN 250 (10")	–	–	55 l/sec.	–	–	–	–
DN 300 (12")	99 l/sec.	–	99 l/sec.	–	–	–	–
DN 400 (16")	175 l/sec.	–	–	–	–	–	–
Filter type	B	A or C	B	B	A	A and C	D
Function of shafts							
Filter shaft	•	•	•	•	•	•	•
Sedimentation shaft	–	–	–	–	–	•	•
Inspection shaft	•	•	•	–	–	–	–
Choke shaft	•	•	•	–	–	–	–
Pump shaft	•	•	•	–	–	–	–
Catalogue page	Page 28	Page 32	Page 34	Page 36	Page 36	Page 37	Page 37

Filter type		Material	Mesh width	Soil volume [l]	Note
Filter type A Filter basket DN 400		PP	0.35 mm (0.01")	15 (4 US gal.)	with lifting device
Filter type B Infiltration filter strainer DN 600		Stainless steel	0.75 mm (0.03")	25 (6.6 US gal.)	with lifting device
Filter type C Telescopic filter basket		galvanised PP	< 0.50 mm (0.02") 0.35 mm (0.01")	20 (5.25 US gal.)	Coarse filter with lifting device Fine filter
Filter type D Settling filter basket		PP	0.35 mm (0.01")	17 (4.5 US gal.)	with lifting device

GRAF Vario 800 flex shaft system

for EcoBloc Inspect flex

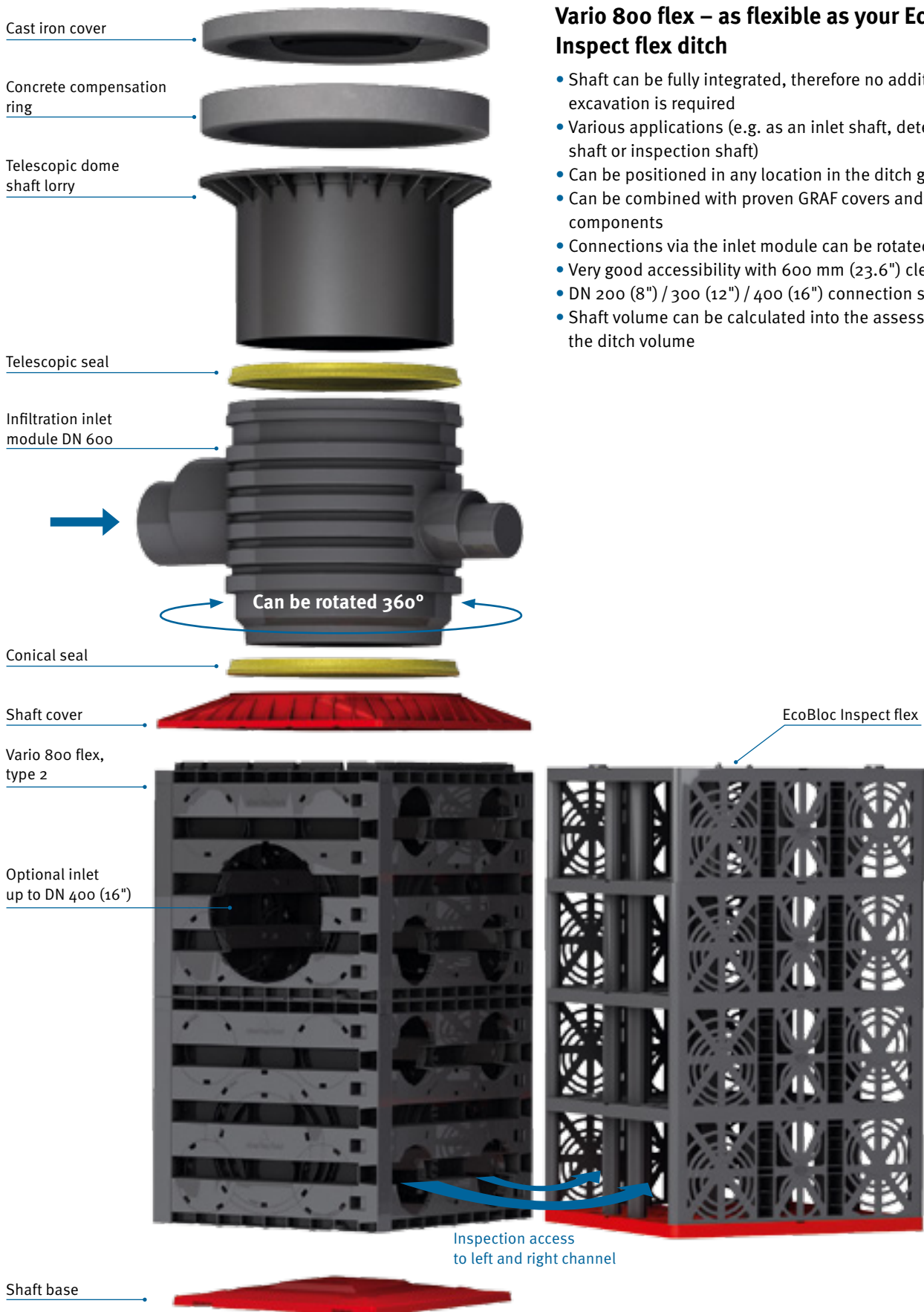

Vario 800 flex – as flexible as your EcoBloc Inspect flex ditch

- Shaft can be fully integrated, therefore no additional excavation is required
- Various applications (e.g. as an inlet shaft, detention shaft or inspection shaft)
- Can be positioned in any location in the ditch grid
- Can be combined with proven GRAF covers and shaft components
- Connections via the inlet module can be rotated 360°
- Very good accessibility with 600 mm (23.6") clearance
- DN 200 (8") / 300 (12") / 400 (16") connection surfaces
- Shaft volume can be calculated into the assessment of the ditch volume

Shaft can be fully integrated

The Vario 800 flex shaft system can be directly installed in an infiltration or detention system with EcoBloc Inspect flex. The connection surfaces of the in-

spection channels in the Vario 800 flex shaft system are accurately matched to the EcoBloc Inspect flex system.



Can be positioned in any location

The dimensions of the Vario 800 flex shaft enable free positioning within the EcoBloc Inspect flex system. The corner position enables the connection of large

pipe diameters of up to DN 400 (16") on the two side panels. The central position offers ideal access to the inspection camera from all directions. Using the

optional inlet module, a connection of up to DN 300 (12") can be made with a freely defined angle.

Can be rotated 360°

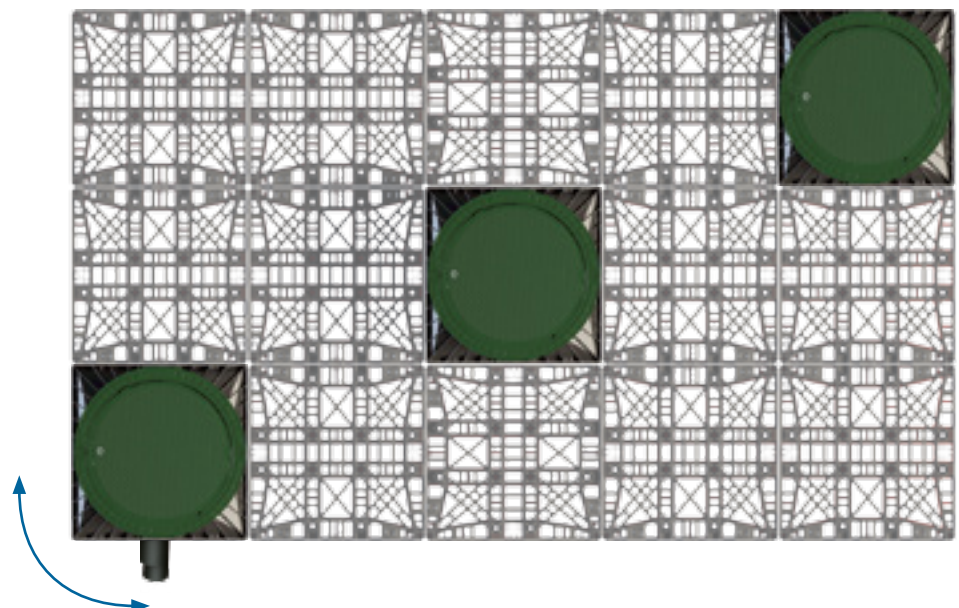

GRAF Vario 800 flex shaft system

for EcoBloc Inspect flex



Vario 800 flex, type 1

shaft body for one layer of EcoBloc Inspect flex

Volume	Length	Width	Height	Weight	Colour	Order no.
230 l (60.7 US gal.)	800 mm (31.4")	800 mm (31.4")	355 mm (14")	16 kg (35.3 lbs)	grey	450050



Vario 800 flex, type 2

shaft body for two or more layers of EcoBloc Inspect flex

Volume	Length	Width	Height	Weight	Colour	Order no.
420 l (113.5 US gal.)	800 mm (31.4")	800 mm (31.4")	660 mm (26")	27 kg (59.5 lbs)	grey	450051



Vario 800 flex, base/cover set

base- and cover for Vario 800 flex shaft

Item	Colour	Order no.
set consisting out of Vario base- and cover plate	grey	450052



Infiltration inlet module DN 600

Incl. profile seal for telescopic dome shaft; DN 150 (6") / DN 200 (8") / DN 250 (10") / DN 300 (12") connections

Order no. 330360



Infiltration connecting piece DN 600

For large installation depths, useful length: 300 mm (11.8")

Order no. 371003

Side view

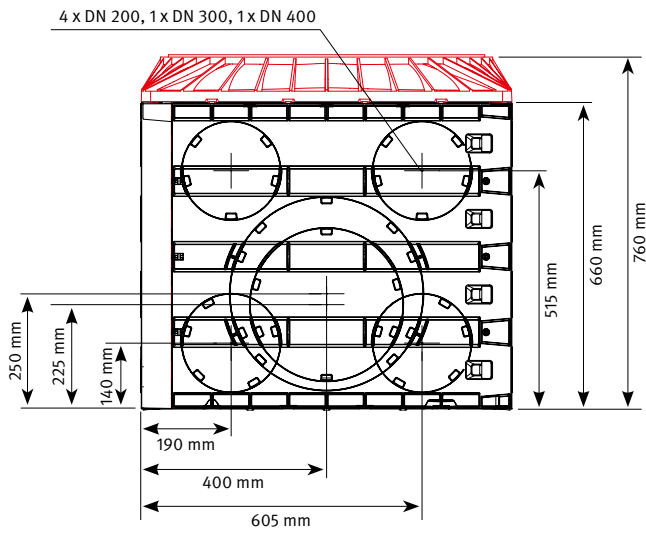

Top view

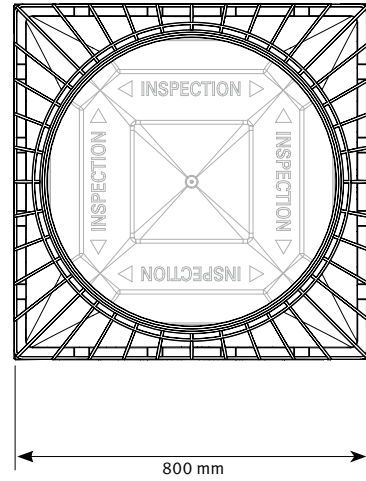

2 x DN 200

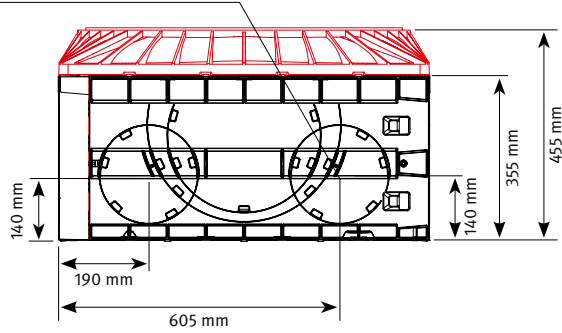

2 x DN 200

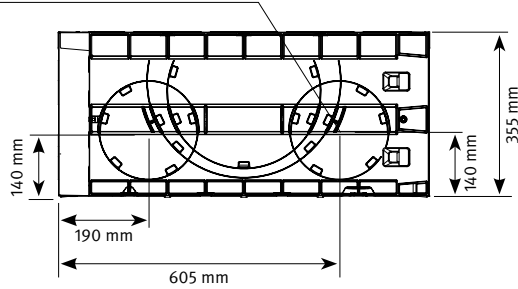

Telescopic dome shaft Mini
plus 140 – 340 mm (5.5" – 13.4")
earth covering

Order no. 371010



Telescopic dome shaft Maxi
plus 140 – 440 mm (5.5" – 17.3")
earth covering

Order no. 371011



Telescopic dome shaft cast iron
plus 140 – 440 mm (5.5" – 17.3")
earth covering

Order no. 371020



Cover to be provided on site

Telescopic dome shaft lorry
plus 140 – 440 mm (5.5" – 17.3")
earth covering

Order no. 371021

GRAF Infiltration shaft system

DN 400

Covers



Telescopic dome shaft 400

With PE cover, suitable for pedestrian loading, colour: grass green

Order no. 340053



Telescopic dome shaft 400

With cast iron cover, suitable for vehicle loading max. load 3.5 t, colour: black

Order no. 340054



Telescopic dome shaft 400

With cast iron cover, lorry-bearing max. load 60 t, colour: black

Order no. 340049



Telescopic filter shaft 400

With slotted cast iron cover, suitable for vehicle loading max. load 3.5 t, incl. coarse filter insert and fine filter basket (0.35 mm (0.01") mesh width), colour: black

Order no. 340126



Individual components

Infiltration inlet module DN 400

Incl. profile seal for telescopic dome shaft; DN 150 (6")/DN 200 (8") connections

Order no. 330339

Infiltration filter basket DN 400 (16")

Mesh width 0.35 mm (0.01")

Order no. 340524



Infiltration connecting piece DN 400

To produce greater installation depths, effective length: 500 mm (19.7"), can be shortened to 250 mm (9.8")

Order no. 330341



Infiltration distributor module DN 400

Incl. profile seal for infiltration connecting piece and/or inlet module; 2 x DN 150 (6") connections; mounting surface for connections of up to DN 150 (6")

Order no. 330340

Retention accessories

Infiltration choke drain

Connection DN 100 (4"); delayed drain of 1.0 (0.26 US gal.)/sec. up to 6.5 l (1.72 US gal.)/sec.

Order no. 330547



[Webcode G9301](#)

GRAF Infiltration shaft system DN 400

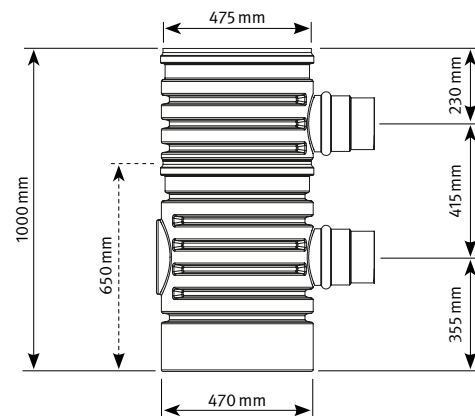
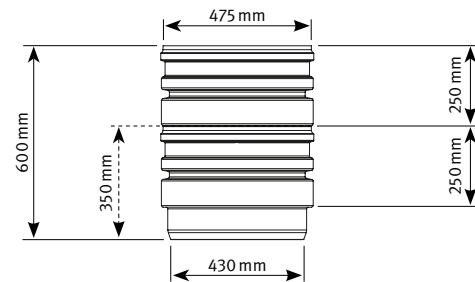
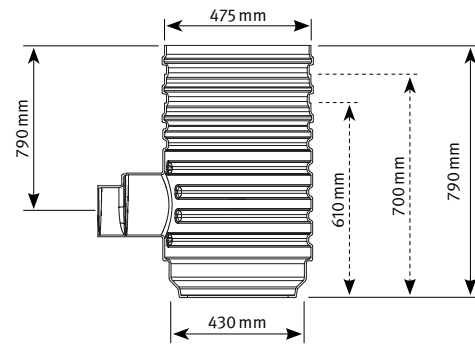
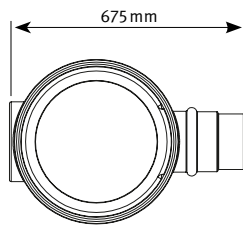
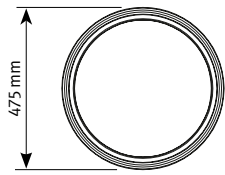
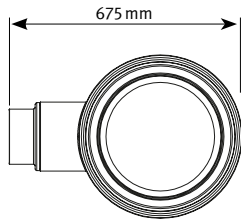

----- Optional cutting edge

Technical data

DN 400	Dimensions	
Overall height [h _{tot}]	min.	1610 mm
	max.	5230 mm
Telescopic height [t]	min.	114 mm
	max.	420 mm
Height of inlet module [h _i]		680 mm
Height of distributor module [h ₂]		1000 mm
Inlet depth [i]	min.	450 mm
	max.	4080 mm
Outlet depth [o ₁]	min.	845 mm
	max.	4465 mm
Outlet depth [o ₂]	min.	1260 mm
	max.	4880 mm
Diameter [d]		475 mm
Connections	Inlet	DN 150/200
	Outlet	2 x DN 150
Ø entry [e]		400 mm

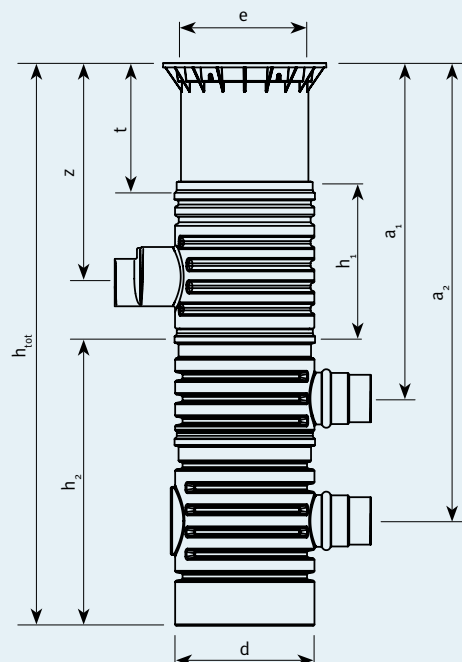

GRAF Infiltration shaft system DN 600

Covers



Telescopic dome shaft Mini

With PE cover, suitable for pedestrian loading, colour: grass green

Order no. 371010



Telescopic dome shaft cast iron

With cast iron cover, suitable for vehicle loading max. load 3.5 t, colour: black

Order no. 371020



Telescopic dome shaft Maxi

With PE cover, suitable for pedestrian loading, colour: grass green

Order no. 371011



Telescopic dome shaft lorry

For common concrete rings, lorry-bearing max. load 60 t, colour: black

Order no. 371021



Individual components



Infiltration inlet module DN 600

Incl. profile seal for telescopic dome shaft; DN 150 (6")/DN 200 (8")/DN 250 (10")/DN 300 (12") connections

Order no. 330360

Infiltration filter strainer DN 600

Made entirely from stainless steel, mesh width 0.75 mm (0.03")

Order no. 340523



Infiltration connecting piece DN 600

To produce greater installation depths, effective length: 300 mm (11.8")

Order no. 371003



Infiltration distributor module DN 600

Incl. profile seal for infiltration connecting piece and/or inlet module; 2 x DN 150 (6") connections; mounting surface for connections of up to DN 150 (6")

Order no. 330361

[Webcode G9302](#)

Retention accessories

Infiltration choke drain

Connection DN 150 (6"); delayed drain of 2 l (0.53 US gal)/sec. up to 16 l (4.22 US gal./sec.)

Order no. 330598



GRAF Infiltration shaft system DN 600

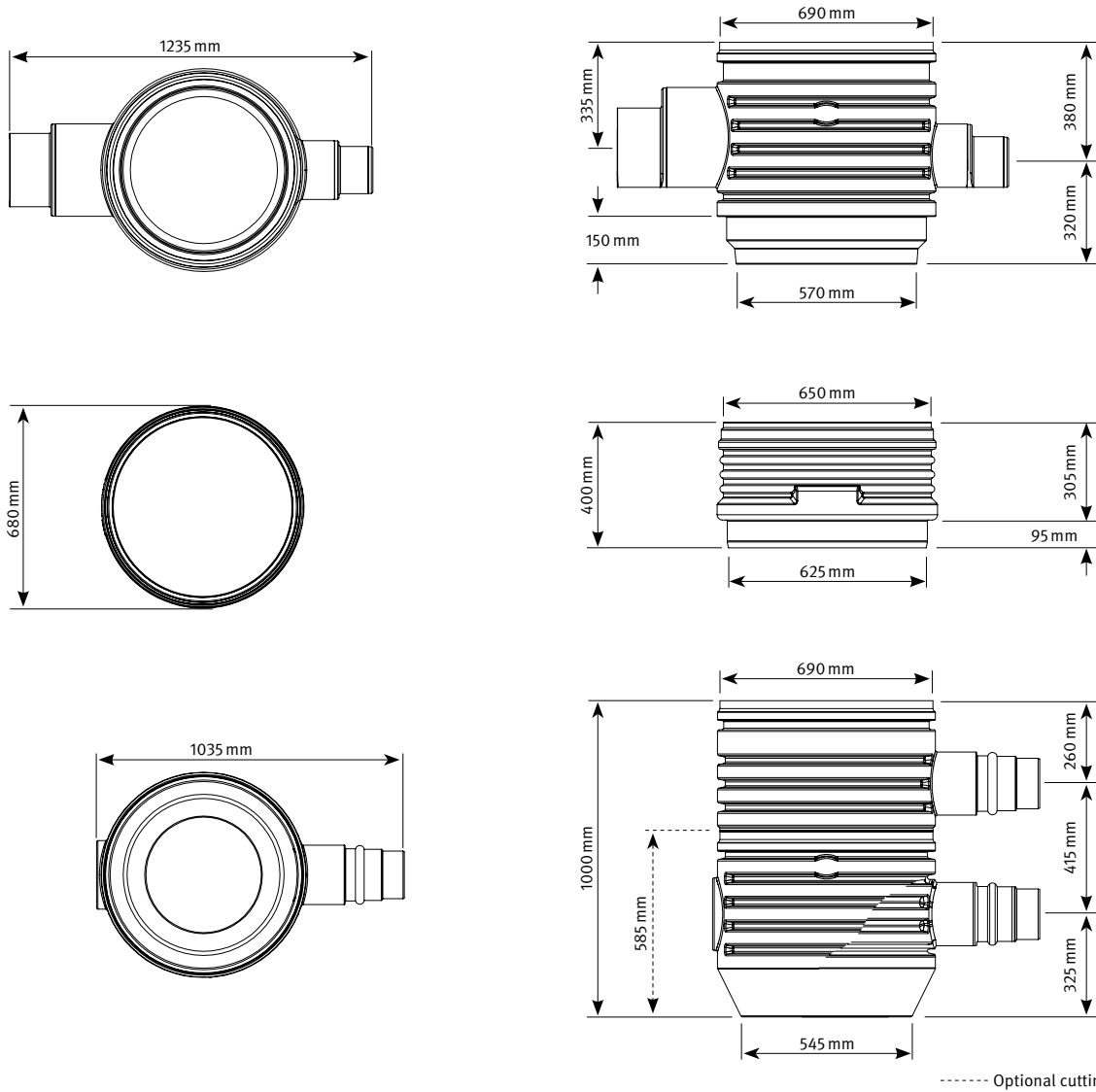

Technical data

DN 600		Dimensions
Overall height [h _{tot}]	min.	1690 mm
	max.	5205 mm
Telescopic height [t]	min.	140 mm
	max.	440 mm
Height of inlet module [h _i]		650 mm
Height of distributor module [h ₂]		1000 mm
Inlet depth [i]	min.	475 mm
	max.	3985 mm
Outlet depth [o ₁]	min.	950 mm
	max.	4465 mm
Outlet depth [o ₂]	min.	1365 mm
	max.	4880 mm
Diameter [d]		690 mm
Connections	Inlet	DN 150/200 DN 250/300
	Outlet	2 x DN 150
Ø entry [e]		600 mm

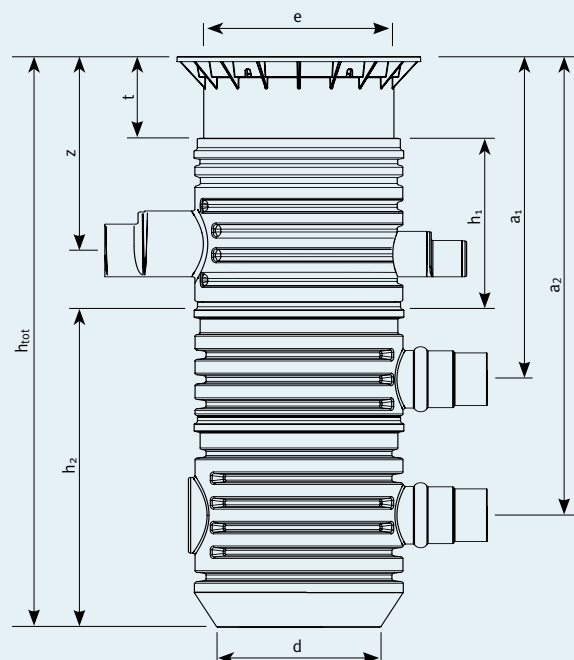

Universal filter



Universal filter 3 external

- 100% water yield therefore ideal for smaller roof areas
- Filter insert mesh width 0.35 mm (0.01")
- Continuously variable installation depth of 600 mm – 1050 mm (22.4 – 41.3") using the telescopic dome shaft
- Lockable, childproof cover
- Flush with ground level
- Minimal height offset 270 mm (10.6") between the inlet and outlet
- Also suitable for infiltration and pond systems
- Maximum flow rate of 5.5 l/sec. with connections DN 100 (4") and 16 l/sec. with DN 150 (6")

Universal filter 3 external

Suitable for pedestrian loading

Order no. 340020

Universal filter 3 external

Suitable for vehicle loading

Order no. 340021

Universal industrial filter 3 external

- For maximum flow rate of up to 29.5 l/sec.
- Continuously variable installation depth of 703–1270 mm (26.7–50.0") using the telescopic dome shaft
- Maximum flow rate of 16 l/sec. with connections DN 150 (6") and 29.5 l/sec. with DN 200 (8")
- Only 229 mm height offset between the inlet and the outlet

Universal industrial filter 3 external

Suitable for pedestrian loading

Order no. 340050

Universal industrial filter 3 external

Suitable for vehicle loading

Order no. 340051



Q Webcode G2205



Filter insert with practical lift-out device

Connection dimensions

① Inlet	273–723 mm
② Outlet	544–944 mm
③ Emergency overflow	273–723 mm

All dimensions from middle of connection to ground level

Replacement filter basket

Order no. 340524

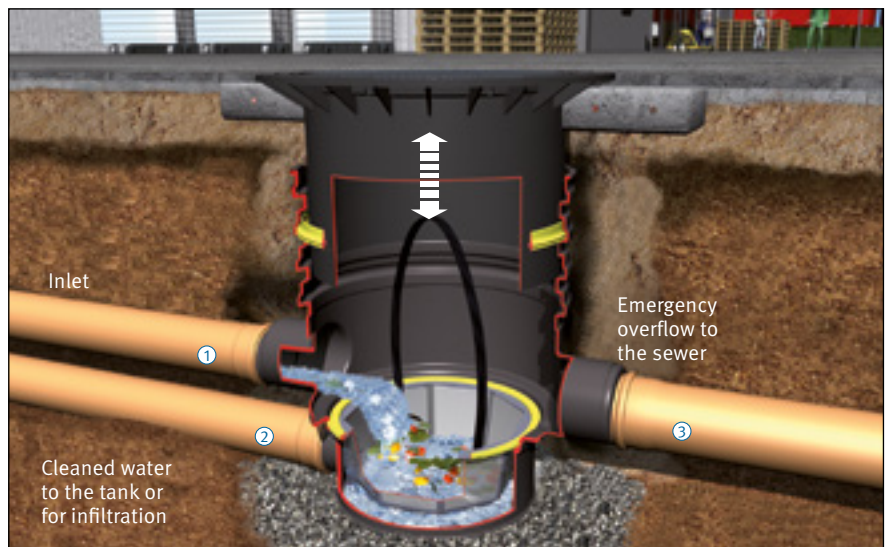

Connection dimensions

① Inlet	DN 150/200	395–962 mm
② Outlet	DN 150	624–1191 mm
③ Emergency overflow	DN 150/200	395–962 mm

Q Webcode G2202

All dimensions from middle of connection to ground level

Infiltration filter shaft

- 3-stage cleaning process
 - ① Coarse filter insert
 - ② Fine filter basket 0.35 mm (0.01") mesh width)
 - ③ Sedimentation zone
- Retains contaminants which may affect infiltration performance
- Ideal as a courtyard inlet structure or a trough-trench overflow element
- Suitable for vehicle loading with cast iron cover 3.5 t
- Continuously variable installation depth of 570 – 1050 mm (22.4" – 41.3") using telescopic dome shaft Ø 400 mm
- Maximum flow rate of 5.5 l/sec. with DN 100 (4") and 16 l/sec. with DN 150 (6")
- DN 100 (4") and DN 150 (6") connections



🔍 **Webcode** 4401

Infiltration connecting piece DN 400

To produce greater installation depths, effective length: 500 mm (19.7"), can be shortened to 250 mm (9.8")

Order no. 330341

Infiltration filter shaft

Suitable for vehicle loading

Order no. 340025

Connection dimensions

④ Outlet 245–725 mm

All dimensions from middle of connection to ground level

Settling filter shaft

- 3-stage cleaning process
 - ① Fine filter basket 0.35 mm (0.01") mesh width)
 - ② Sedimentation zone
 - ③ Immersion pipe as separator
- Continuously variable installation depth of 900– 1600 mm (2' 11.4"–5' 3") using telescopic dome shaft Ø 600 mm
- Pedestrian loading with plastic cover, or suitable for vehicle loading with cast iron cover 3.5 t
- Lockable childproof cover
- Sealed to top edge of ground
- Maximum flow rate of 16 l/sec. with DN 150 (6")
- DN 150 (6") connections



🔍 **Webcode** 4402

Infiltration connecting piece DN 600

For large installation depths, useful length: 300 mm (11.81")

Order no. 371003

Settling filter shaft

pedestrian loading

Order no. 340026

Settling filter shaft

Suitable for vehicle loading

Order no. 340027

Connection dimensions

④ Inlet 380–1080 mm

⑤ Outlet 630–1330 mm

All dimensions from middle of connection to ground level

Rainwater detention / retention



Rainwater detention and retention with limited outlet

Detention

Detention systems, i.e. rainwater detention, play an important role in the reduction of hydraulic peaks and thus help relieve strain on the public sewer network, particularly in new construction areas. Detention systems usually consist of a volume which is used for the temporary storage of rainwater in the event of heavy rainfall, and a throttling device to limit the draining runoff water. The rainwater is cleaned using a filter before it enters the detention volume in order to avoid compromising the function of the throttling device. The throttled flow of rainfall is fed into the sewer and the excess amount is retained in the deten-

tion cistern. This amount accumulates in the detention cistern and is also drained off with the throttled runoff water after the rainfall event. The detention volume is thus discharged and remains available once more as a temporary storage tank for the next rainfall event.

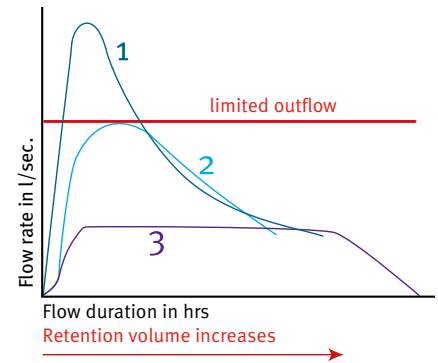

1. Outflow rate without throttle
2. Outflow rate with static throttle
3. Outflow rate with dynamic throttle

Retention

The GRAF retention cistern is a combination of rainwater retention and rainwater harvesting. The detention can be larger if required. In this case, part of the rainwater can also be used in addition to the required detention volume. For example, rainwater can be used for the following applications:

- Watering gardens
- Flushing toilets
- Washing machines
- Cleaning

The use of rainwater means that up to 50% of drinking water can be saved, and up to 85% for commercial properties.

The retention cistern is designed such that the rainwater first fills the usage volume. When the useful volume is full, the throttled outflow is activated and the detention volume also becomes available for temporary storage. The detention mechanism with throttled outflow in turn corresponds to a conventional retention system. Following the rainfall event, the position of the outflow prevents the detention cistern from being completely emptied, while the usage volume remains in the tank!

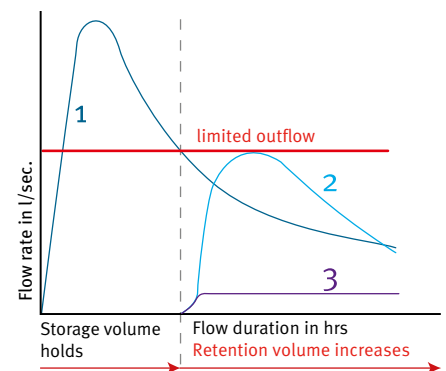

1. Outflow rate without throttle
2. Outflow rate with static throttle
3. Outflow rate with dynamic throttle

	Detention	Retention
Rainwater detention	✓	✓
Rainwater harvesting		✓

Rainwater detention with GRAF EcoBloc Inspect flex

In the event of heavy rainfall, a controlled discharge of rainwater to the sewer system is of increasing importance. The amount of rain from a storm is thus distributed evenly over a longer period of time. The GRAF EcoBloc

Inspect flex is enclosed in a three-layer structure, which prevents the uncontrolled drainage of water from the ditch. EcoBloc Inspect flex ditches to relieve the sewer system are generally provided with throttled drainage. These can be

integrated into the GRAF Vario 800 flex shaft system, among others. The position of the shaft can be freely defined.

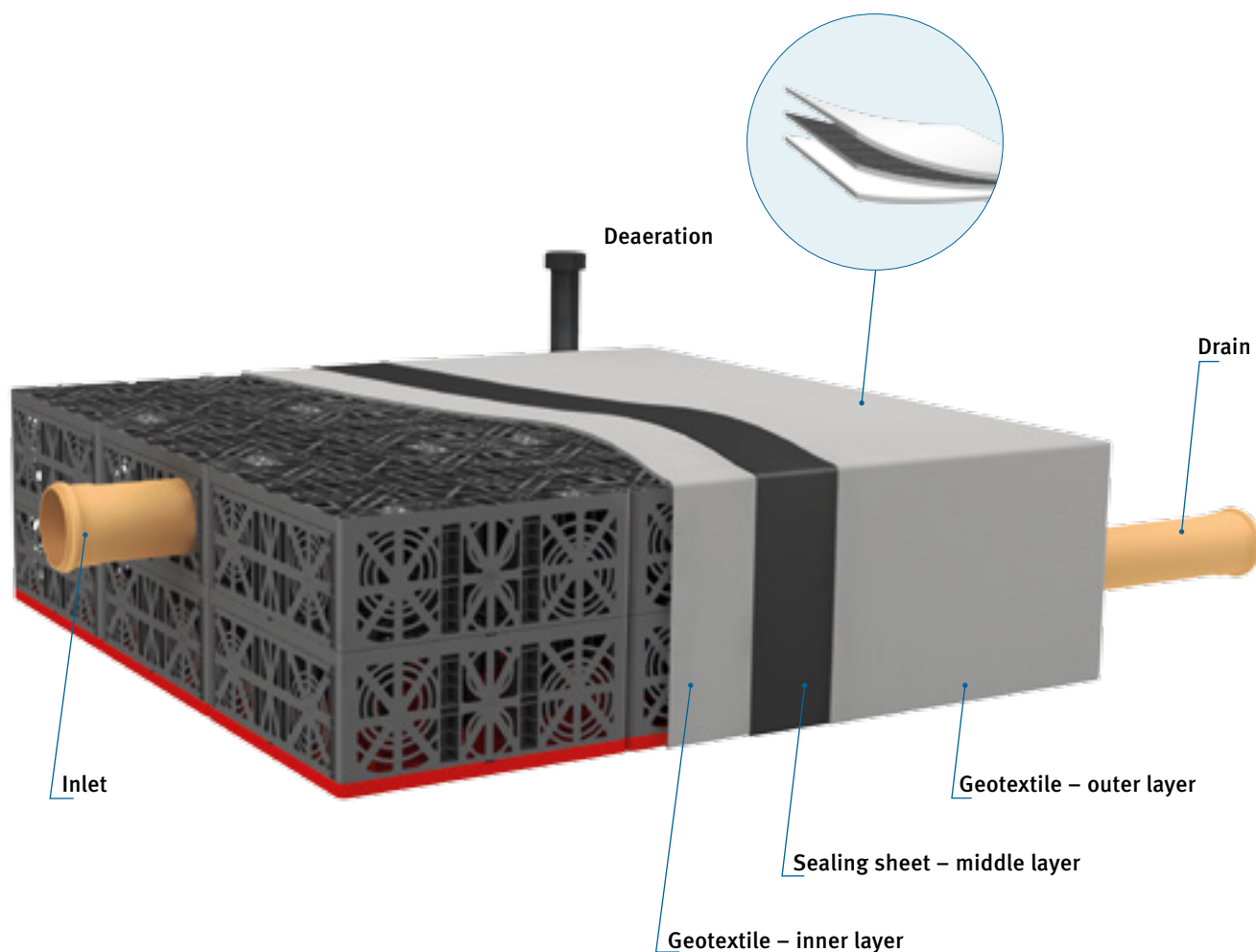

Detention systems with GRAF EcoBloc Inspect flex

The detention volume required can be made up of tanks as well as ditch elements. The ditch elements are wrapped in geotextile. Next there is a watertight layer with an impermeable film of cor-

responding strength (tip: HDPE film, min. 2mm (0.08") thick). The two layers are once more wrapped in geotextile. The inner layer of geotextile protects the watertight film from sharp block edges,

while the outer geotextile prevents damage from the surrounding earth or stones.

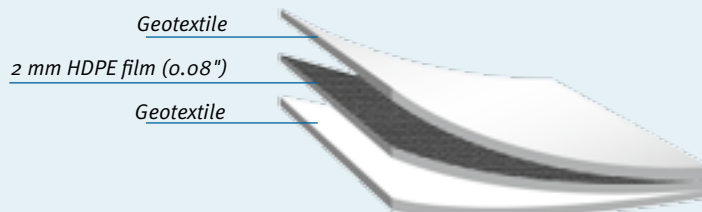

Detention with GRAF EcoBloc Inspect flex

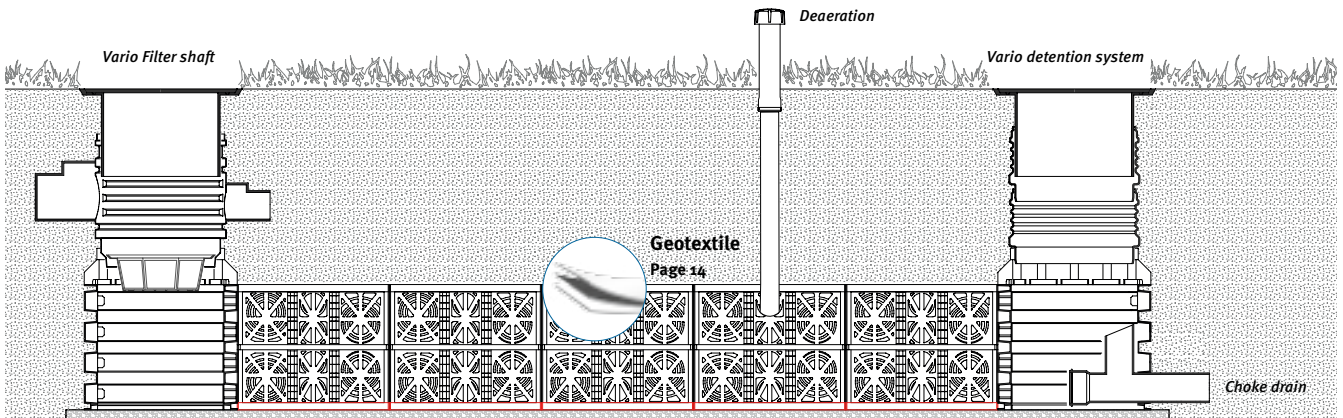

Rainwater harvesting with GRAF EcoBloc Inspect flex

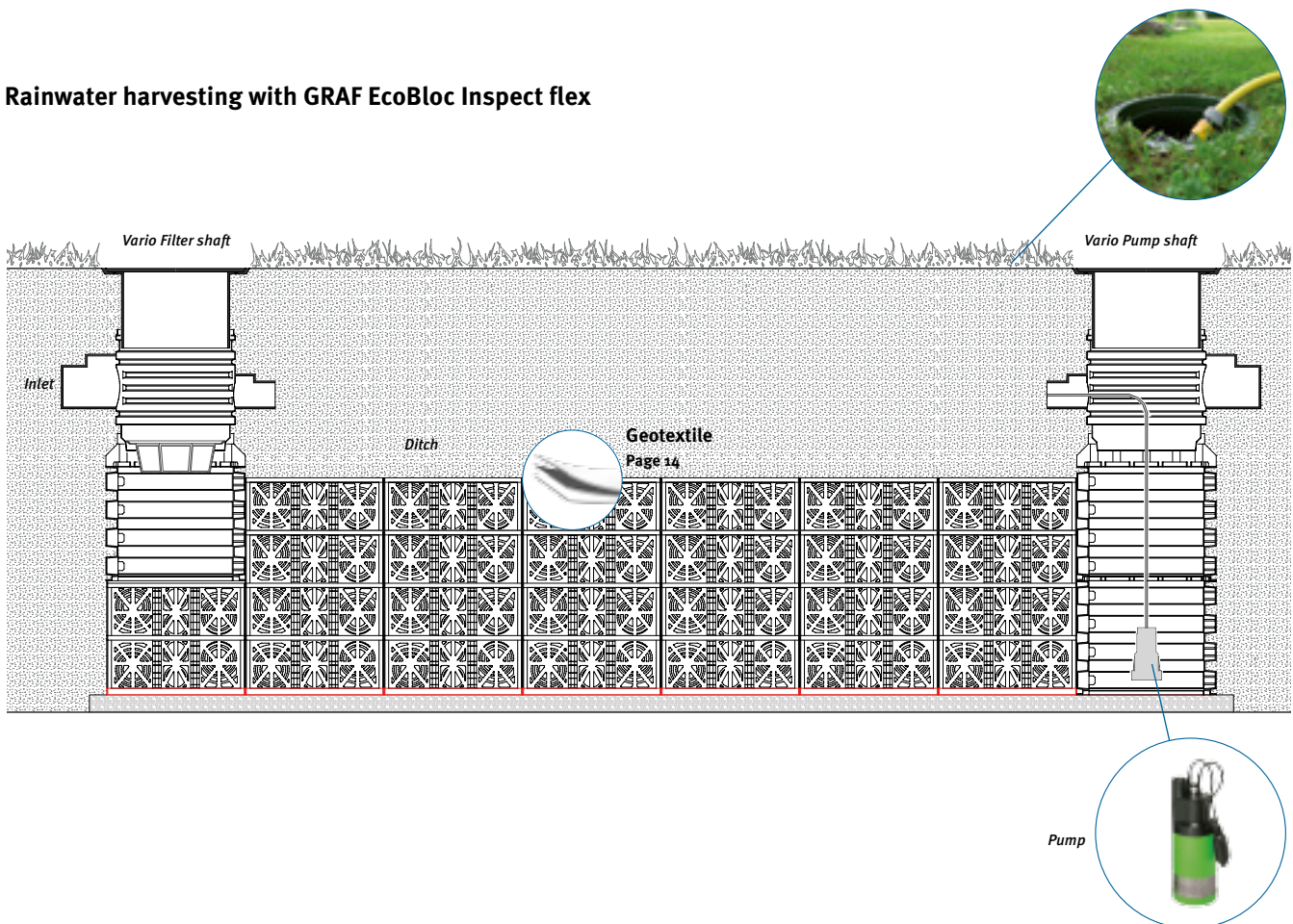

Carat S underground tank Detention cistern

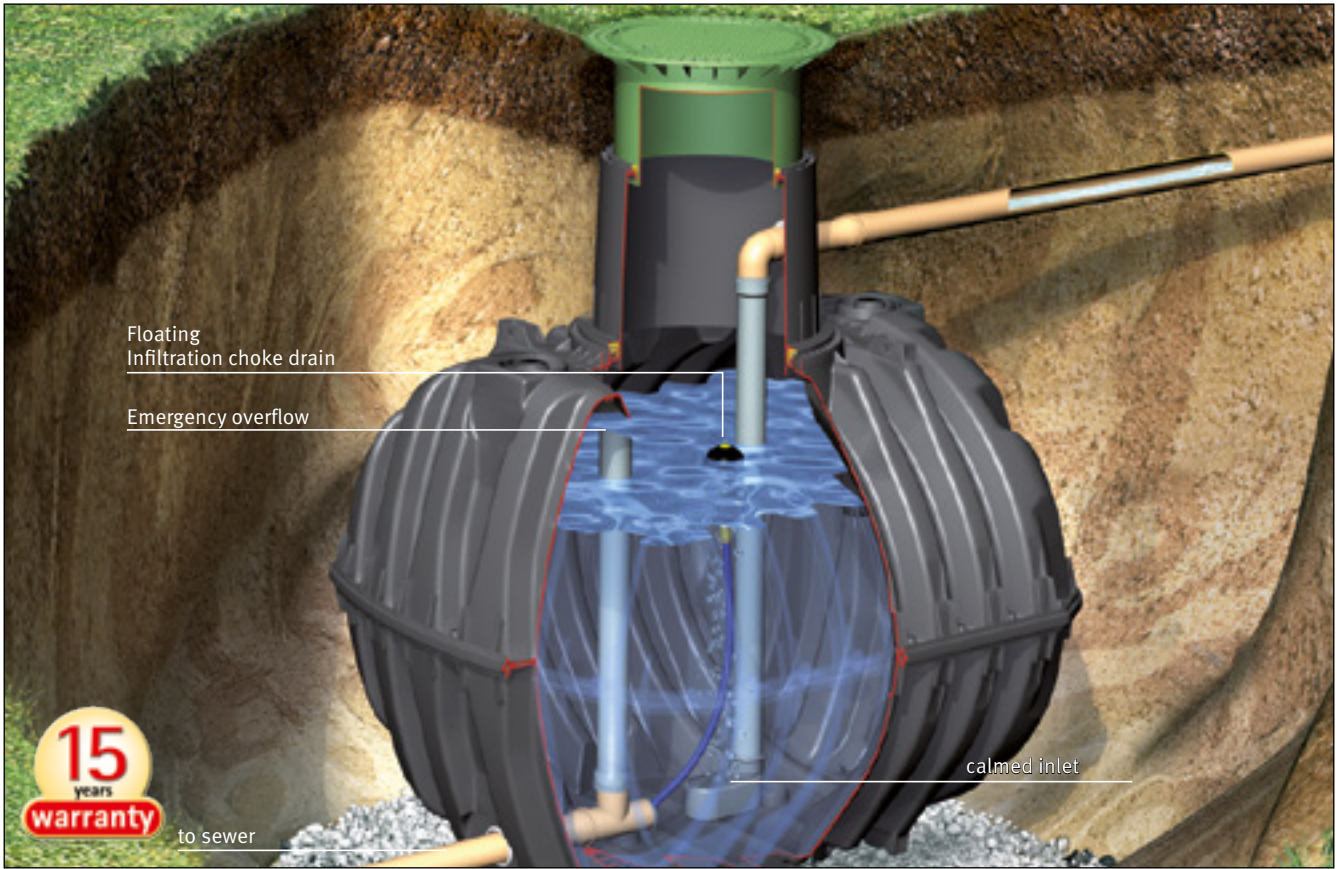
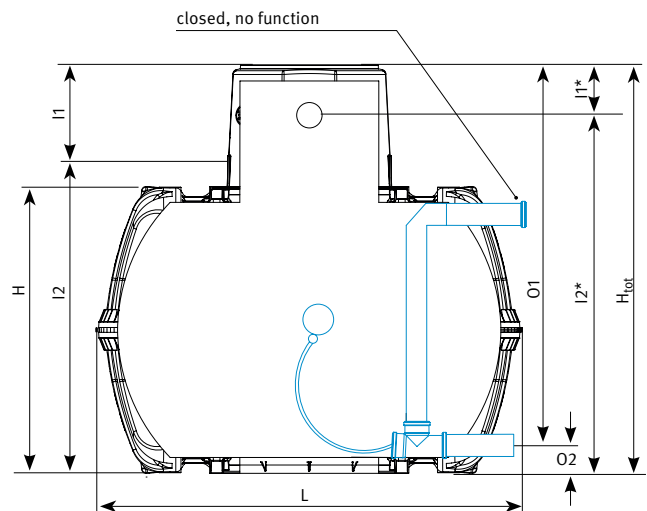

Figure shows Carat S detention cistern, Carat S tank on page 52, tank dome and cover on page 54/55

Webcode G4301

Carat S Choke drain
package detention / retention
0.05 – 2.0 l (0.01–0.53 US gal.)/sec.,
DN 100 (4") connection, 3 m hose
Order no. 369020

**HIGHER OUTFLOWS
ON REQUEST**



Carat S underground tank detention cistern

Capacity [litres]	Width W [mm]	Length L [mm]	Height H_{tot} [mm]	Height H [mm]	Inlet I1 [mm]	Inlet I2 [mm]	Inlet I1* [mm]	Inlet I2* [mm]	Outlet O1 [mm]	Outlet O2 [mm]
2,700	1565	2080	1690	1400	520	1490	245	1955	1530	160
3,750	1755	2280	2200	1590	520	1680	245	2185	2040	160
4,800	1985	2280	2430	1820	520	1910	245	2465	2270	160
6,500	2190	2390	2710	2100	520	2190	790	1920	2550	160

Please refer to the installation instructions for groundwater installation and loading capacity.

Carat S underground tank Retention cistern

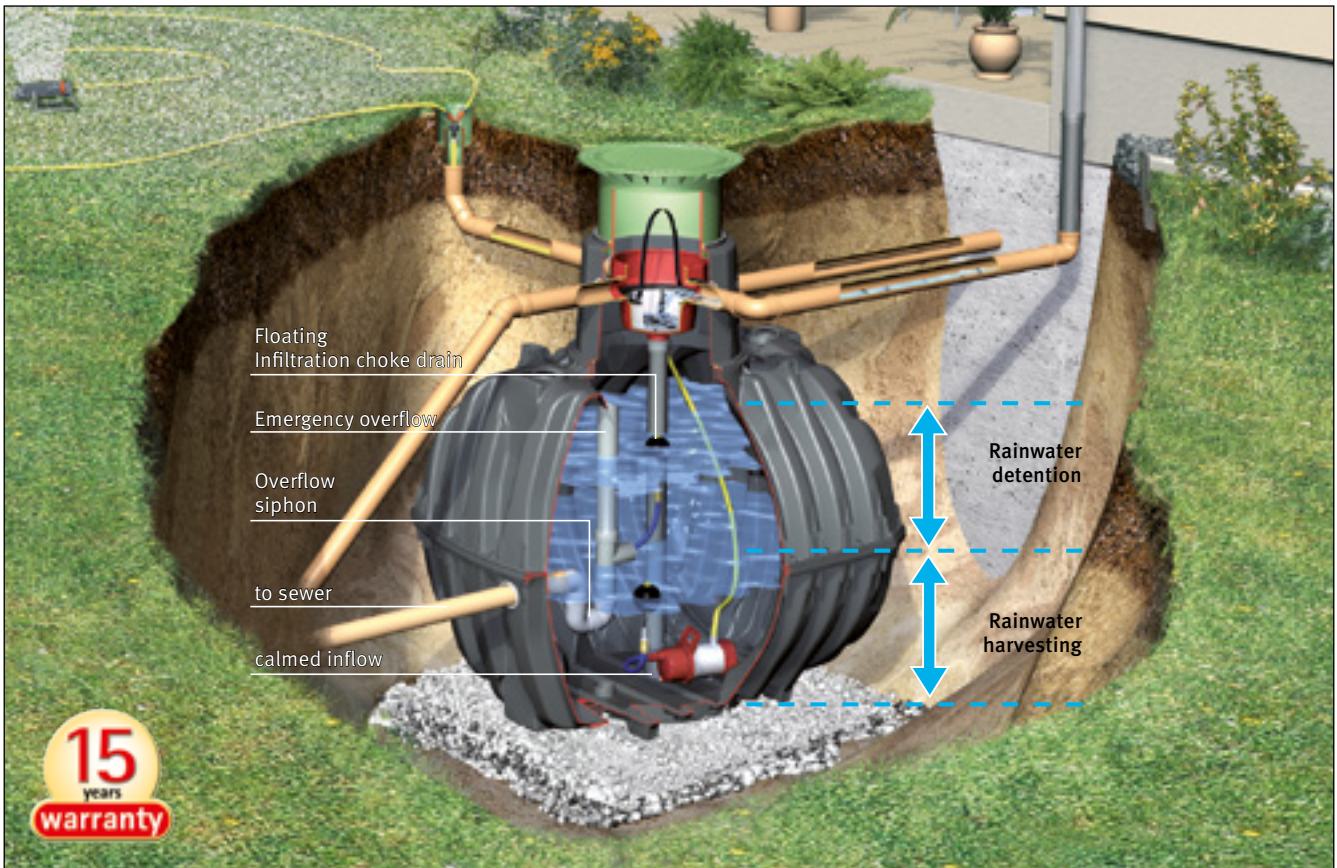
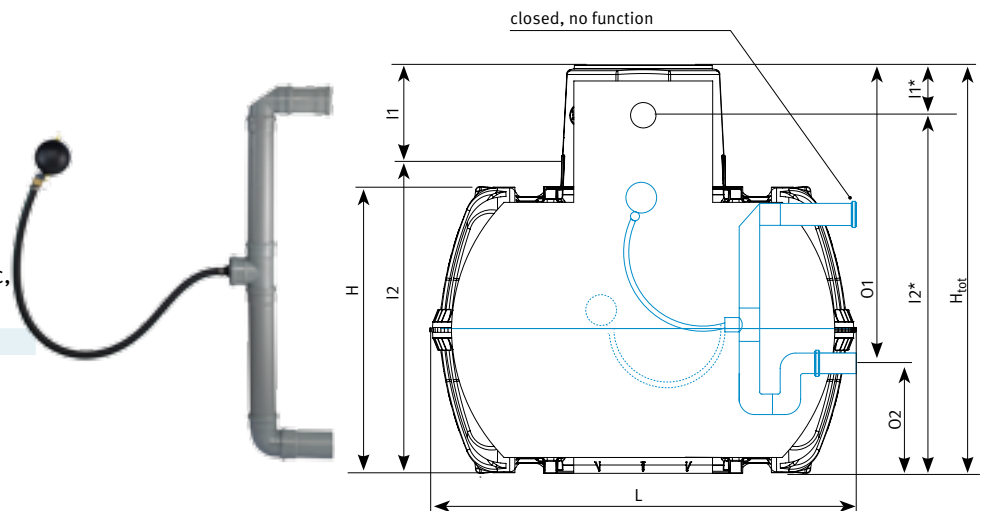

Figure shows Carat S retention cistern with Carat S filter package 2 and Garden Comfort technical package, Carat S tank on page 52, tank dome and cover on page 54/55

Webcode G4302

Carat S Choke drain
package detention / retention
0.05 – 2.0 l (0.01–0.53 US gal.)/sec,
DN 100 (4") connection, 3 m hose
Order no. 369020

**HIGHER OUTFLOWS
ON REQUEST**



Carat S underground tank retention cistern

Capacity [litres]	Detention volume [litres]	Useage volume [litres]	Width W [mm]	Length L [mm]	Height H _{tot} [mm]	Height H [mm]	Inlet I ₁ [mm]	Inlet I ₂ [mm]	Inlet I ₁ * [mm]	Inlet I ₂ * [mm]	Outlet O ₁ [mm]	Outlet O ₂ [mm]
3,750	1,500	2,250	1755	2280	2200	1590	520	1680	245	1955	2040	160
4,800	2,000	2,800	1985	2280	2430	1820	520	1910	245	2185	2270	160
6,500	3,000	3,500	2190	2390	2710	2100	520	2190	245	2465	2550	160

Please refer to the installation instructions for groundwater installation and loading capacity.

Platin flat tank Detention cistern

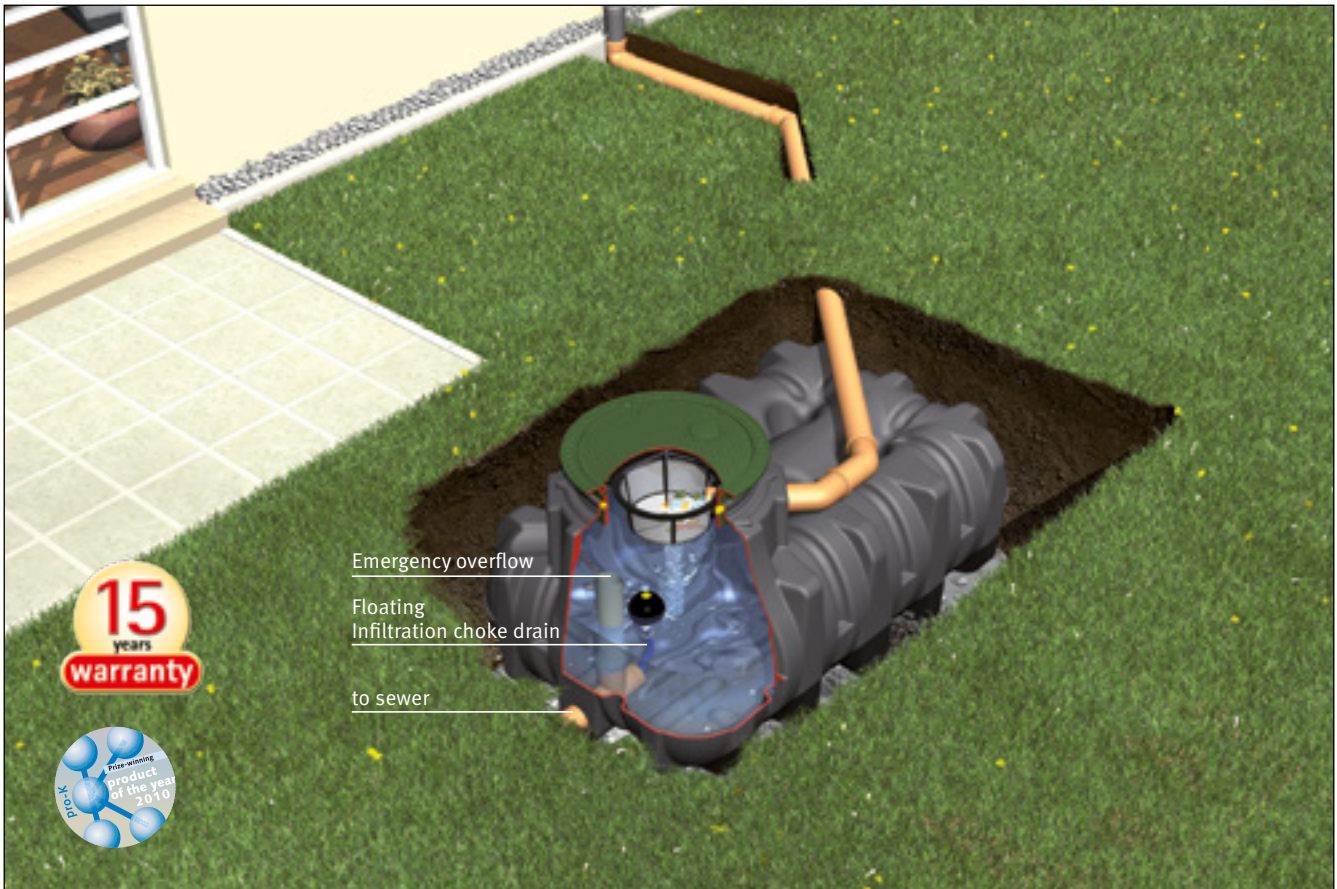
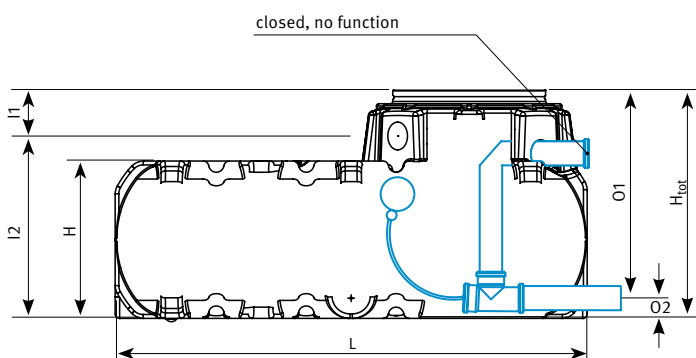

Figure shows Platin detention cistern with Platin filter package 2

[Webcode G4303](#)



Volume [litres]	Detention volume [litres]	Order no.
1,500	1,500	390300
3,000	3,000	390301
5,000	5,000	390302
7,500	7,500	390305
10.000 ¹⁾	10.000 ¹⁾	390304

Scope of supply: Platin tank, floating choke drain and hose. Cover has to be ordered separately, page 55

Platin flat tank detention cistern

Volume [litres]	Width W [mm]	Length L [mm]	Height H _{tot} [mm]	Height H [mm]	Inlet I ₁ [mm]	Inlet I ₂ [mm]	Outlet O ₁ [mm]	Outlet O ₂ [mm]
1,500	1250	2100	1015	700	185	830	925	90
3,000	2100	2450	1050	735	185	865	960	90
5,000	2300	2890	1265	950	185	1080	1175	90
7,500	2250	3600	1565	1250	185	1380	1475	90

Please refer to the installation instructions for groundwater installation and loading capacity.

Platin flat tank Retention cistern

THE VOLUME DISTRIBUTION (DETENTION VOLUME/USAGE VOLUME) CAN BE INDIVIDUALLY MANUFACTURED ACCORDING TO YOUR SPECIFICATIONS.

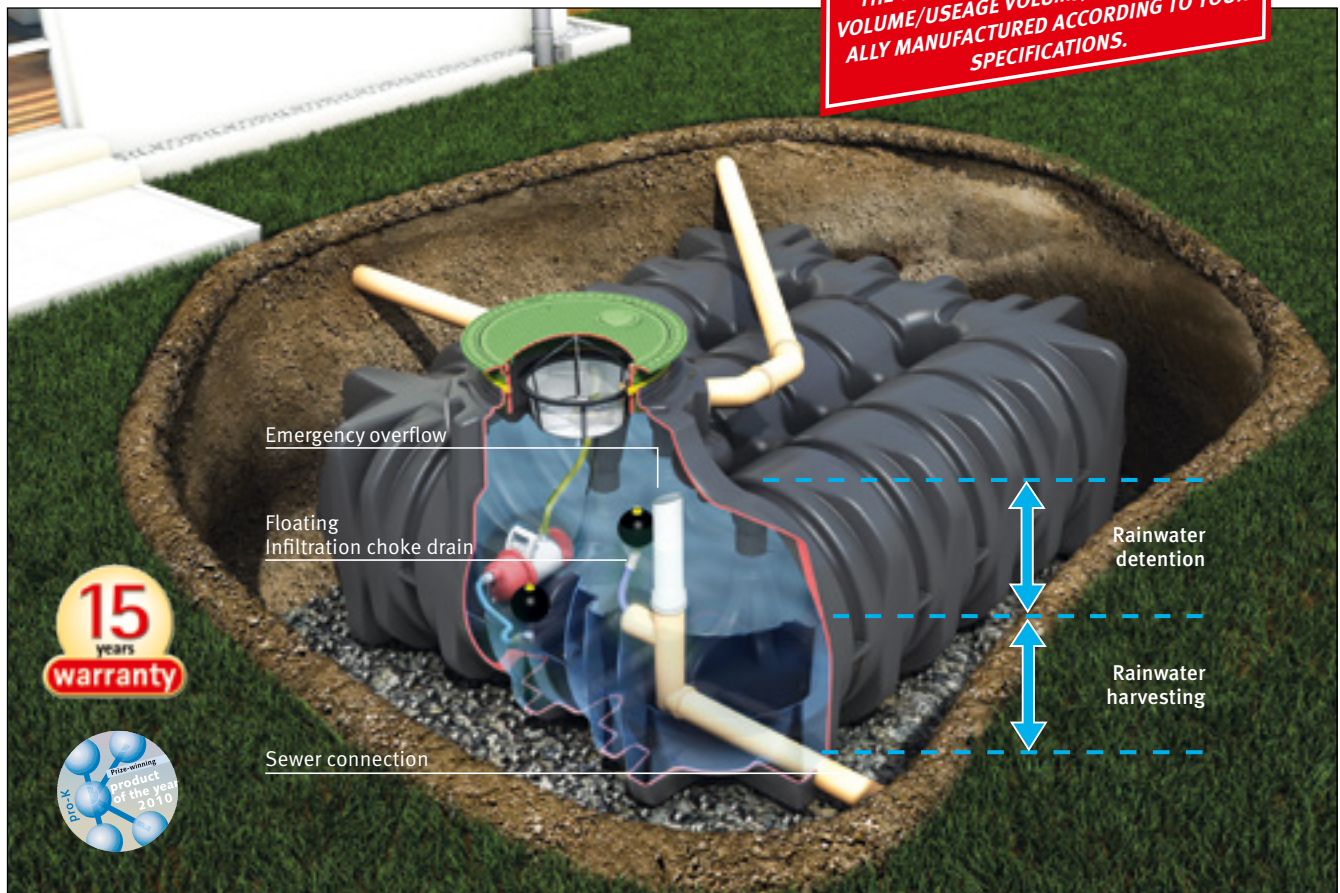
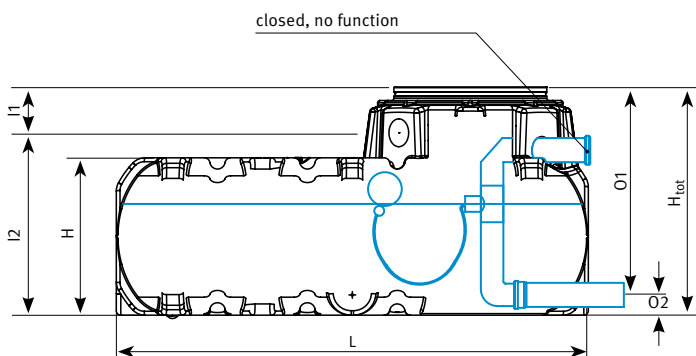

Figure shows Platin retention cistern with Platin filter package 2 and Garden Comfort technical package

[Webcode G4304](#)



Volume [litres]	Detention volume [litres]	Usage volume [litres]	Order no.
3,000	3,000	2,000	390312
5,000	4,500	3,000	390315
7,500	6,000	4,000	390324
10.000 ³⁾	6,000	4,000	390321

Scope of supply: Platin tank, floating choke drain and hose.
Cover has to be ordered separately, page 55

Platin flat tank retention cistern

For combined rainwater detention and rainwater harvesting, including retention accessories

Volume [litres]	Width W [mm]	Length L [mm]	Height H _{tot} [mm]	Height H [mm]	Inlet I ₁ [mm]	Inlet I ₂ [mm]	Outlet O ₁ [mm]	Outlet O ₂ [mm]
3,000	2100	2450	1050	735	185	865	960	90
5,000	2300	2890	1265	950	185	1080	1175	90
7,500	2250	3600	1565	1250	185	1380	1475	90

Please refer to the installation instructions for groundwater installation and loading capacity.

³⁾ Set consisting of two Platin flat tanks
Further sizes upon request!

Carat XL underground tank detention / retention cistern



Carat XL underground tank Suitable for vehicle / lorry 12 t

- Suitable for HGV loading up to 12 t
- Can be mounted in groundwater
- Lower weight than concrete and steel
- Various connection surfaces DN 100 (4") / 150 (6")
- Investment security thanks to a 15 year warranty
- Can be used as detention or retention cistern



THE VOLUME DISTRIBUTION (DETENTION VOLUME/USAGE VOLUME) CAN BE INDIVIDUALLY MANUFACTURED ACCORDING TO YOUR SPECIFICATIONS.

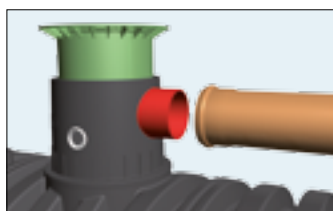

Larger connection fittings upon request



Webcode G1103

Figure shows 10,000 l tank with cast iron telescopic dome suitable for vehicle loading

Carat XL underground tank detention cistern

Total volume / Detention volume	Weight	Order no.
8,500 l (2,242 US gal.)	380 kg (838 lbs)	370504
10,000 l (2,640 US gal.)	456 kg (1,005 lbs)	370505

Technical data

max. axle load:	8 t
max. total weight:	12 t
Earth covering with loading capacity:	800 – 1500 mm (2' 7.5" – 4' 11")
Groundwater stability:	up to the middle of the tank
Earth covering with groundwater installation:	800–1500 mm (2' 7.5"–4' 11")
Connection options:	DN 100 (4") / DN 150 (6") DN 200 (8") on top
Tank dome inner Ø:	650 mm (25.6")

Carat XL underground tank retention cistern

Total volume	Detention volume	Usage volume	Order no.
8,500 l (2,242 US gal.)	3,500 l (923 US gal.)	5,000 l (1320 US gal.)	370523
10,000 l (2,640 US gal.)	4,000 l (1055 US gal.)	6,000 l (1583 US gal.)	370525

Scope of supply: Carat XL underground rainwater tank with Maxi tank dome, choke drain and hose

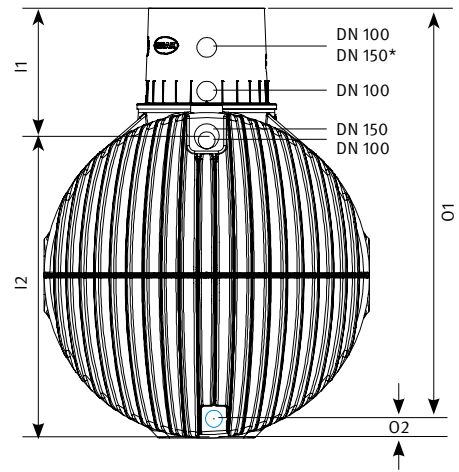
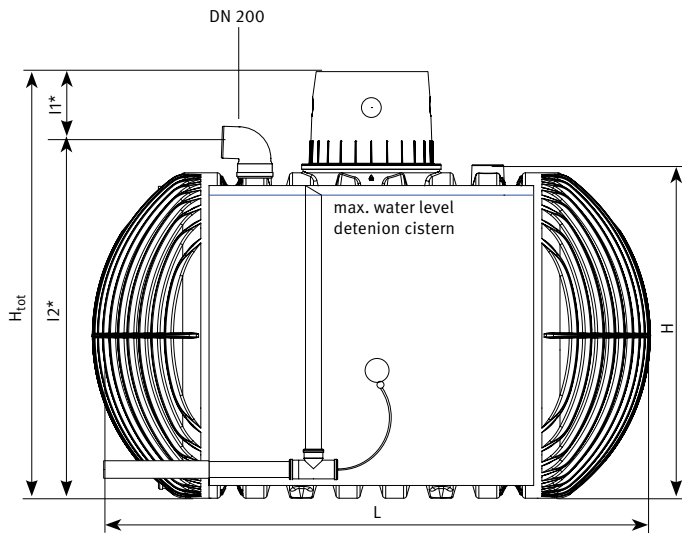

*optional

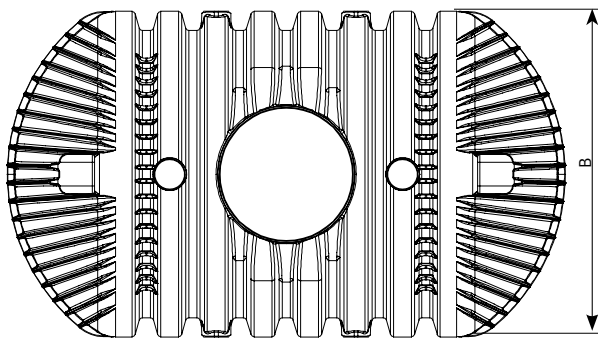

Figure shows tank without cover. The total installation height results from the total tank height (H_{tot}) plus the telescopic dome shaft (page 55).

Carat XL underground tank detention and retention cistern

Volume [litres]	Width W [mm]	Length L [mm]	Height H_{tot} [mm]	Height H [mm]	Inlet I1 [mm]	Inlet I2 [mm]	Inlet I1* [mm]	Inlet I2* [mm]	Outlet O1 [mm]	Outlet O2 [mm]
8,500	2040	3500	2695	2085	805	1890	435	2625	2585	110
10,000	2240	3520	2895	2285	805	2090	435	2625	2785	110

Carat XXL underground tank

up to 76,000 litres



Carat XXL underground tank Suitable for vehicle/lorry 40 t

- Suitable for HGV loading up to 40 t
- Can be mounted in groundwater
- Lower weight than concrete and steel
- Various connection surfaces
DN 100 (4")/150 (6")/200 (8")
- Available with DN 300 (12") connection as an option
- Available with a second tank dome as an option
- 76,000 litres (20,050 US gal.) Volume possible
- Investment security thanks to a 15 year warranty

DN 300 (12")
connection on
end face upon
request

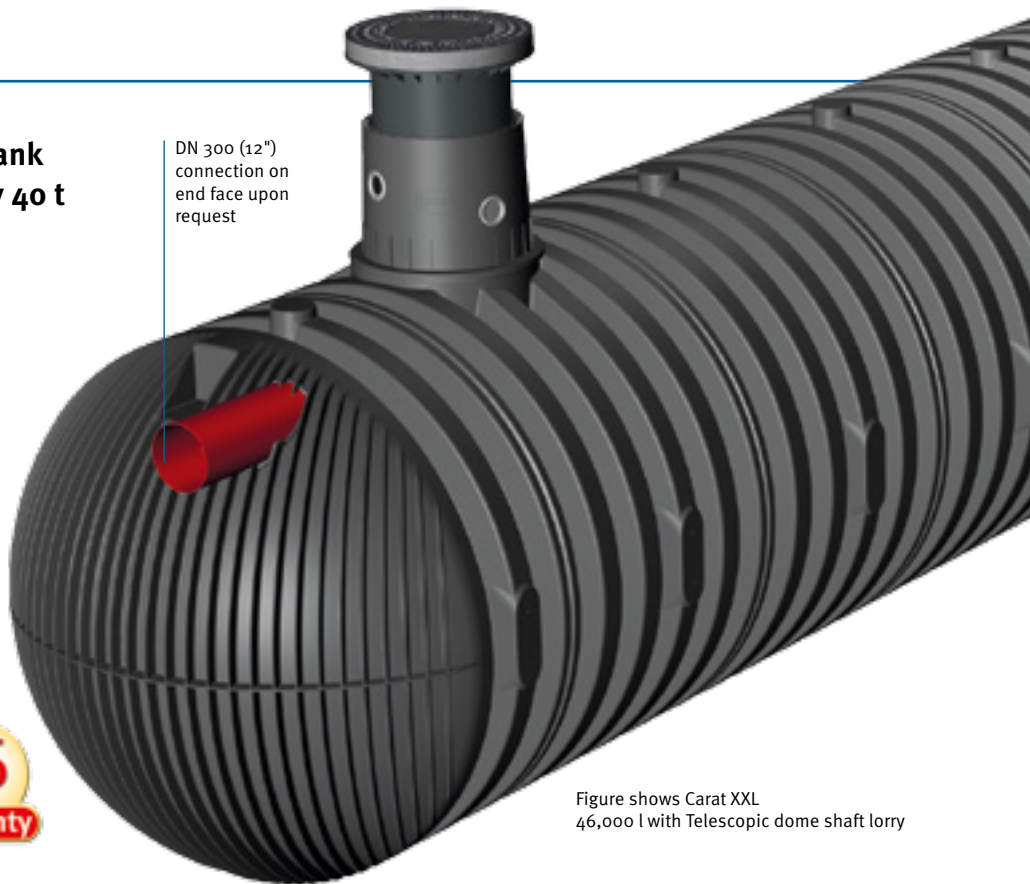
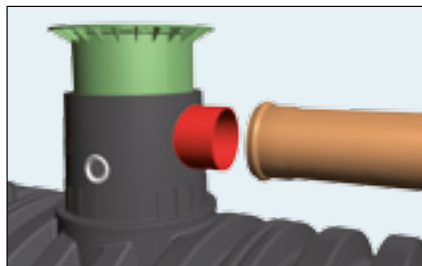
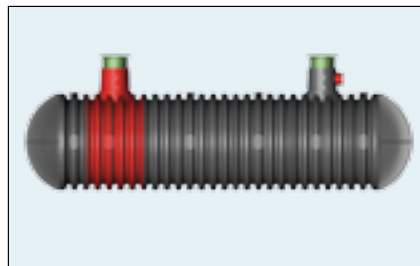

Figure shows Carat XXL
46,000 l with Telescopic dome shaft lorry



Carat XXL available with DN 300 (12") connection as an option



Carat XXL available with a second tank dome as an option

CARAT XXL AVAILABLE AS DETENTION AND RETENTION CISTERNS. CAN BE INDIVIDUALLY MANUFACTURED ACCORDING TO YOUR SPECIFICATIONS.

Carat XXL underground rainwater tank

Capacity [litres]	Tank dome inner Ø [mm]	Weight [kg]	Order no.
16,000	650	805	380001
22,000*	650	1015	380000
26,000	650	1150	380002
32,000*	650	1360	380003
36,000	650	1495	380004
42,000*	650	1705	380005
46,000	650	1840	380006
52,000*	650	2050	380007
56,000	650	2185	380008
62,000*	650	2395	380009
66,000	650	2530	380010
72,000*	650	2740	380011
76,000	650	2875	380012

up to 100,000 litres upon request

*with a second tank dome

Scope of supply: Carat XL underground rainwater tank with Maxi tank dome, choke drain and hose

[Webcode G1104](#)



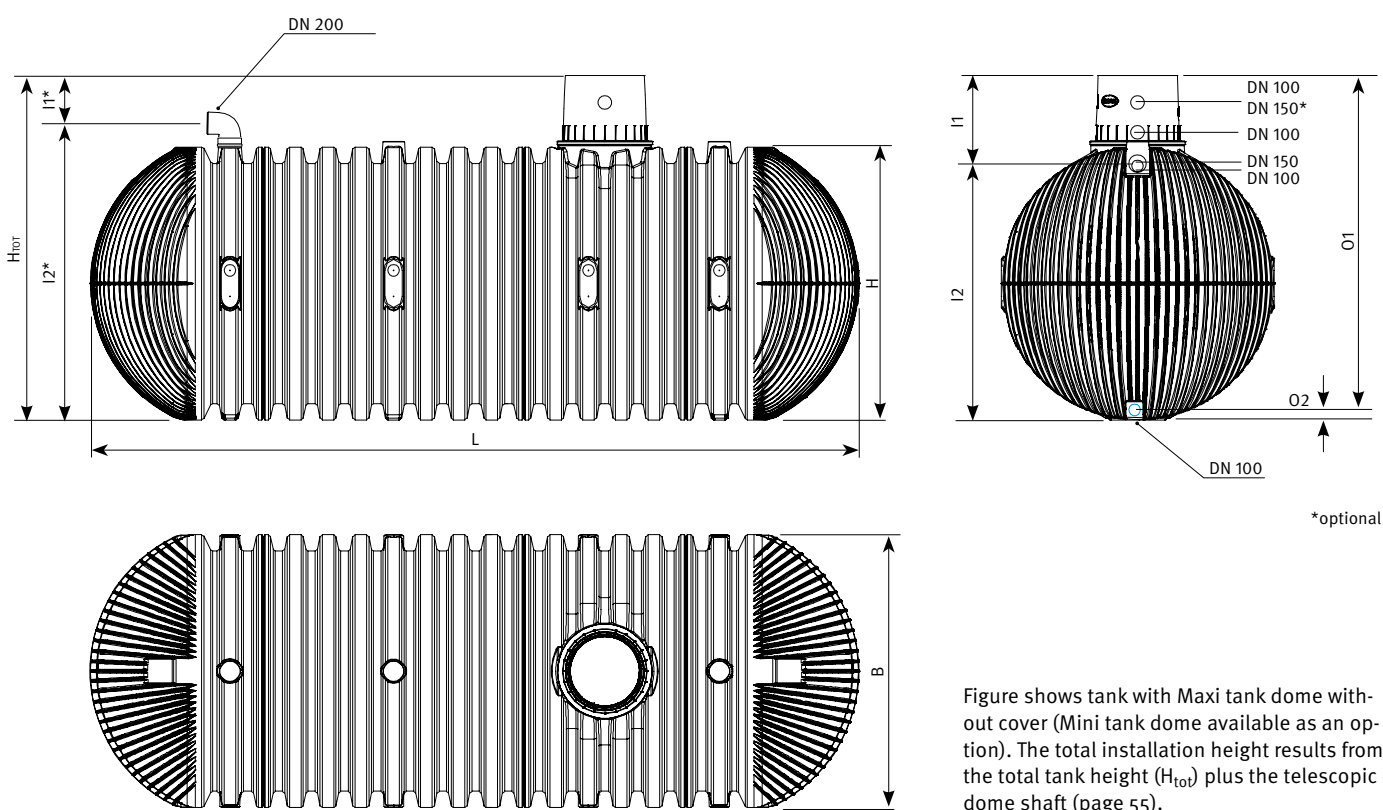

Figure shows tank with Maxi tank dome without cover (Mini tank dome available as an option). The total installation height results from the total tank height (H_{tot}) plus the telescopic dome shaft (page 55).

Carat XXL underground rainwater tank

Capacity [litres]	Width W [mm]	Length L [mm]	Height H_{tot} [mm]	Height H [mm]	Inlet I1 [mm]	Inlet I2 [mm]	Inlet I1* [mm]	Inlet I2* [mm]	Outlet O1 [mm]	Outlet O2 [mm]
16,000	2500	4660	3160	2550	800	2360	435	2725	3070	90
22,000*	2500	6145	3160	2550	800	2360	435	2725	3070	90
26,000	2500	7045	3160	2550	800	2360	435	2725	3070	90
32,000*	2500	8530	3160	2550	800	2360	435	2725	3070	90
36,000	2500	9430	3160	2550	800	2360	435	2725	3070	90
42,000*	2500	10915	3160	2550	800	2360	435	2725	3070	90
46,000	2500	11815	3160	2550	800	2360	435	2725	3070	90
52,000*	2500	13300	3160	2550	800	2360	435	2725	3070	90
56,000	2500	14200	3160	2550	800	2360	435	2725	3070	90
62,000*	2500	15685	3160	2550	800	2360	435	2725	3070	90
66,000	2500	16585	3160	2550	800	2360	435	2725	3070	90
72,000*	2500	18070	3160	2550	800	2360	435	2725	3070	90
76,000	2500	18970	3160	2550	800	2360	435	2725	3070	90

up to 100,000 litres upon request
 *with a second tank dome

Technical data

max. axle load:	8 t
max. total weight:	3.5 t with cast iron cover, 40 t with telescopic dome shaft lorry
Earth covering with loading capacity:	800–1500 mm (2' 7.5"–4' 11")
Groundwater stability:	up to the middle of the tank
Earth covering with groundwater installation:	800–1500 mm (2' 7.5"–4' 11")
Connection options:	DN 100 (4")–DN 200 (8")

Herkules detention cistern

The detention cistern with unequalled value for money. Thanks to its patented design, the transport of the Herkules Infiltration tank is very easy. The two tank halves can be assembled on site, and the patented quick connection system enables easy, tool-free installation in just a few minutes. By using the interconnecting pipe sets, the system can be extended at will. Patent no. in Europe 0870877 and USA no. 587807



**1600 LITRES
(422 US GAL.)**

Technical data

Volume	1,600 litres (422 US gal.)
Max Ø	1350 mm (53")
Height	1600 mm (63")
Material	fibre-glass reinforced PP (UV stable and 100% recyclable)
Weight	approx. 60 kilos
Connections	each 2 x DN 70 (2.8"), DN 100 (4") and DN 200 (8")

Herkules detention cistern

1600 litres (422 US gal.)
without support pipe

Order no. 320001

[Webcode G1301](#)

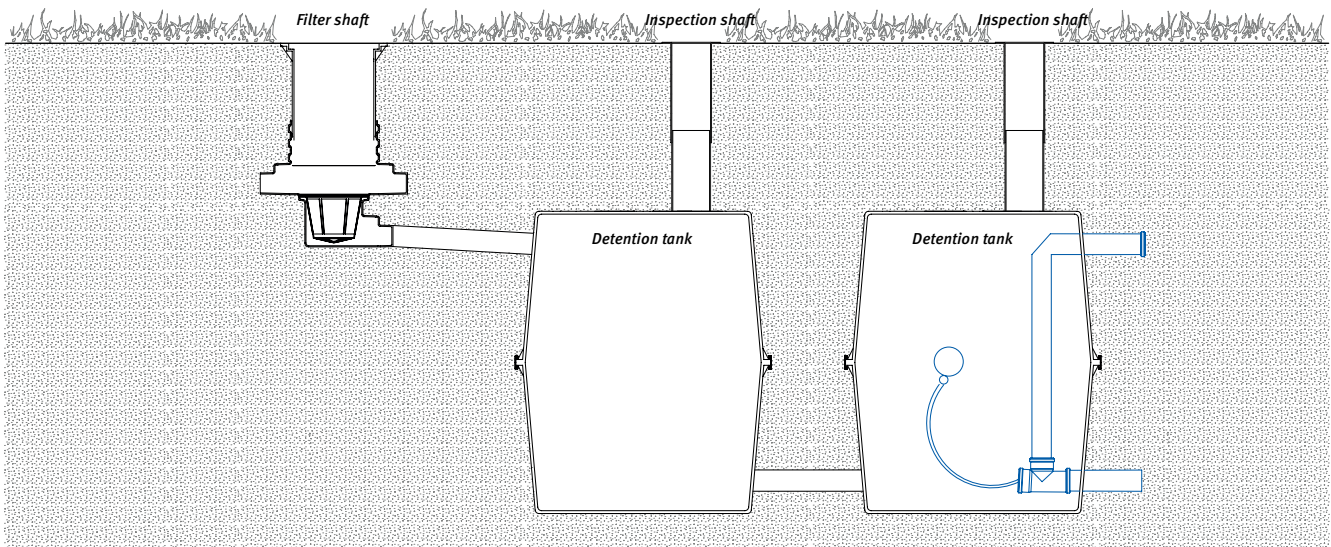

Practical advantages of Herkules

Ease of transport

Each half of the Herkules-Tank only weighs 30 kg. This allows ease of transport and manual installation. The tank halves fit through any doorway (80 cm width and above).

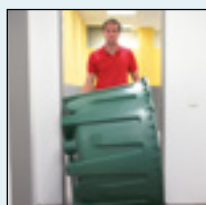

Easy to install



Several tanks can be combined



Herkules Infiltration tank

The Infiltration tank with unequalled value for money. Thanks to its patented design, the transport of the Herkules Infiltration tank is very easy. The two tank halves can be assembled on site, and the patented quick connection system enables easy, tool-free installation in just a few minutes. By using the interconnecting pipe sets, the system can be extended at will. Patent no. in Europe 0870877 and USA no. 5878907



Technical data

Volume	1,600 litres (422 US gal.)
Max Ø	1350 mm (53")
Height	1600 mm (63")
Material	fibre-glass reinforced PP (UV stable and 100% recyclable)
Weight	approx. 60 kilos
Connections	each 2 x DN 70 (2.8"), DN 100 (4") and DN 200 (8")

Herkules Infiltration tank
Including support pipe
Order no. 200201

Accessories for Herkules detention cistern and Herkules Infiltration tank

Cut-out tool (with pilot drill)

DN 70 (2.8")	Order no. 202002
DN 100 (4")	Order no. 202003

Interconnecting pipe set (without cut-out tool)

DN 70 (2.8")	Order no. 202029
DN 100 (4")	Order no. 202028

Tank dome

(with telescopic end 1 m (3.3') to be cut on demand)



DN 200 (8")	Order no. 322026
-------------	------------------

Support pipe for Herkules tank

required for underground assembly

DN 150 (6")	Order no. 322014
-------------	------------------

GRAF-Tex geotextile

For one Herkules Infiltration Tank

Order no. 369015



Material sold by the metre, roll width 5 m (15.2')

Order no. 231002

Further application possibilities



Rainwater harvesting solutions

For more information about our Herkules Rainwater tank please refer to our brochure R31 EN



The modular system Carat S

Choose your tank size

Carat S underground tank for vehicle loading

Size 2,700 – 6,500 litres (700 – 1,700 US gal.). Designed to be used in conjunction with the vehicle loading telescopic dome shaft. The access dome is designed in accordance to DIN testing.

Illustration shows 4,800 litre (1,250 US gallon) tank with telescopic dome shaft for pedestrian loading

Volume [litres]	Order no.
2,700 (700 US gal.)	372024
3,750 (1,000 US gal.)	372025
4,800 (1,250 US gal.)	372026
6,500 (1,700 US gal.)	372027

Tank dome Maxi

(page 54)

Order no. 371040



Tank dome Mini

(page 54)

Order no. 371041



Technical data

Dimensions / weight	2,700 litres 700 US gal.	3,750 litres 1,000 US gal.	4,800 litres 1,250 US gal.	6,500 litres 1,700 US gal.
Length	2080 mm (81.9")	2280 mm (89.8")	2280 mm (89.8")	2390 mm (94.1")
Width	1565 mm (61.6")	1755 mm (69.1")	1985 mm (78.2")	2190 mm (86.2")
Height (including tank dome)	2010 mm (79.1")	2200 mm (86.6")	2430 mm (95.7")	2710 mm (106.7")
Height of tank dome	610 mm (24.0")			
Internal Ø tank dome	800 mm (31.5")			
Weight	120 kg (265 lbs.)	150 kg (331 lbs.)	185 kg (408 lbs.)	220 kg (485 lbs.)
Load				
Max. axle load	Suitable for vehicle loading			
Earth covering	800 - 1200 mm (31.5 - 47.2")			
Groundwater				
Groundwater-stable	Up to the middle of the tank			
Earth covering	800 mm - 1000 mm (31.5" - 39.4")			

Benefits of the Carat S system

Sealed, stable, unique

1 Flush with ground level (2 seals)

The Carat S underground tank has numerous seals to effectively stop dirt getting into the tank. This means that seepage water cannot get into the tank and, thus, dirt particles cannot contaminate the rainwater. The seals are in the intersection between the tank and the tank dome and between the tank dome and the telescopic dome shaft. All supply pipes connected to the tank dome are also sealed with five lip seals as standard.

2 Encircling stabilisation ring in unique H profile

The Carat S underground tank has an unique profile for more stability and security. Thanks to the additional ribbing, the Carat S underground tank suffers no significant warping even under extreme loads. Therefore, the Carat S underground tank is suitable for vehicle loading in principle up to a total weight of 3.5 t, groundwater-stable up to the middle of the tank and can be installed with an earth covering up to 1.2 m. Additionally, the encircling H profile acts as a convenient carry handle for transport and as a tread when fitting the tank dome. Please follow our installation instructions for this (can also be downloaded at www.graf.info).

3 Ribbed tank base

The tank base of the Carat S underground tank is extremely stable thanks to the numerous ribs. These enable the Carat S to be installed in groundwater up to the middle of the tank. Furthermore, the stable base means the tank is very robust for transportation to site. The tank base has already proven its excellent rigidity in numerous computer simulations during the development process. Please follow our installation instructions for this purpose (can also be downloaded at www.graf.info).

An overview of further advantages

- Highest stability thanks to modern production methods
- Unique fit accuracy of the components thanks to new production processes
- Consistent quality through TÜV safety testing and production monitoring
- Suitable for vehicle loading (when combined with the telescopic cast iron page 55)
- Groundwater-stable up to the middle of the tank thanks to the extremely stable construction
- Easy to transport due to low weight and encircling H profile
- Investment security thanks to 15-year warranty – compare it!
- Can be expanded as often as required

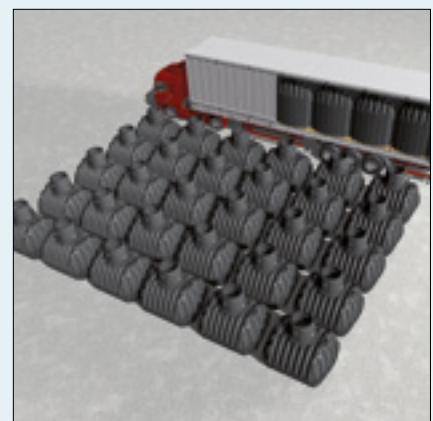

Tank dome



Tank dome Mini

- Weight: 11 kg
- For especially flat installation
- incl. 3 edge seals

Order no. 371040

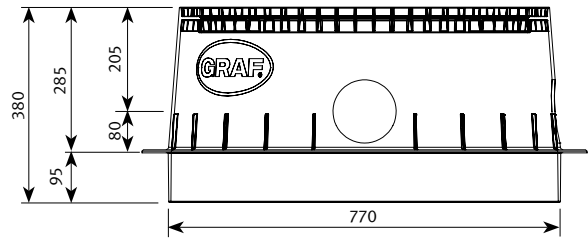

Tank dome Maxi

- Weight: 15 kg
- For large earth coverings (loading capacity)
- incl. 5 edge seals

Order no. 371041

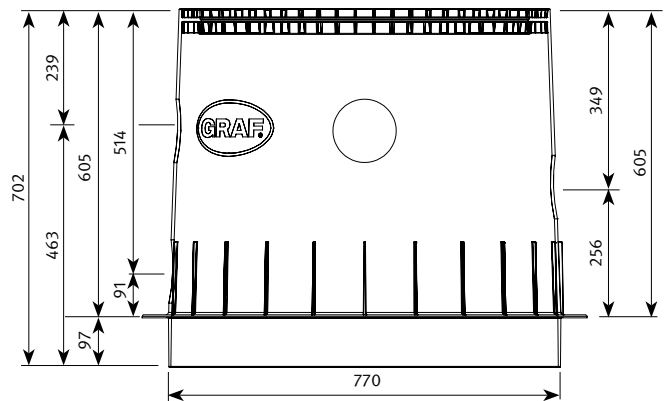

Tank dome Micro

- Weight: 7 kg
- including green lid
- for shallow excavation
- earth cover only 90mm

Order no. 371009

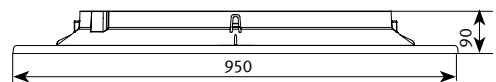

Extension for shafts and domes

- Weight: 6 kg
- The earth covering can be raised 300 mm using the spacer.

Order no. 371003

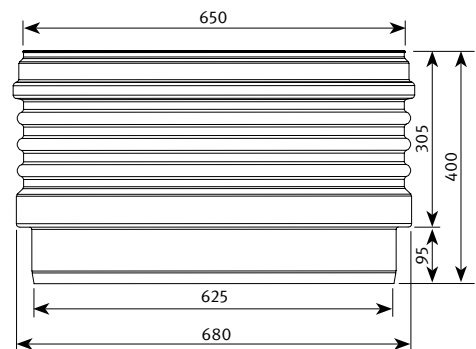



Telescopic dome shaft Mini

- with PE cover
- suitable for pedestrian loading
- Weight: 9 kg
- Adjustable earth covering across upper tank surface

plus 140–340 mm earth covering

Order no. 371010

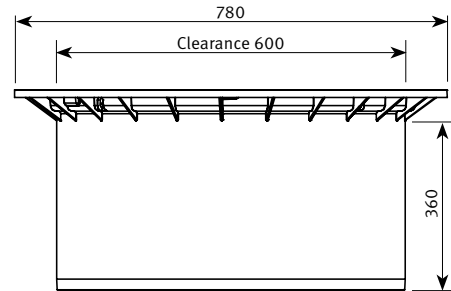

Telescopic dome shaft Maxi

- with PE cover
- suitable for pedestrian loading
- Weight: 15 kg
- Adjustable earth covering across upper tank surface

plus 140–440 mm earth covering

Order no. 371011

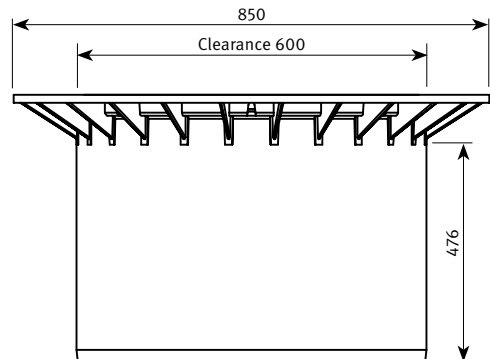

Telescopic dome shaft cast iron

- Suitable for vehicle loading – with childproof cast iron cover up to 3.5 t
- Weight: 55 kg
- Adjustable earth covering across upper tank surface

plus 140–440 mm earth covering

Order no. 371020

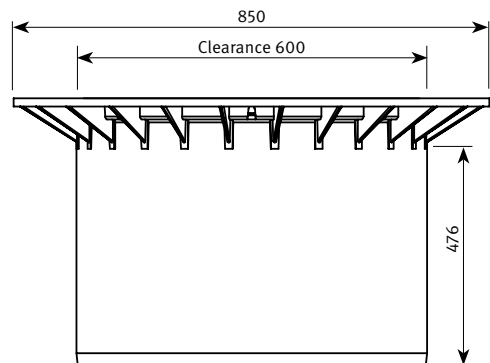

Telescopic dome shaft lorry

- Suitable for vehicle/HGV loading
- Weight: 11 kg
- Cover to be provided on site
- Adjustable earth covering across upper tank surface
- For commercially available concrete rings/covers (to be provided on site)

plus 140–440 mm earth covering

Order no. 371021

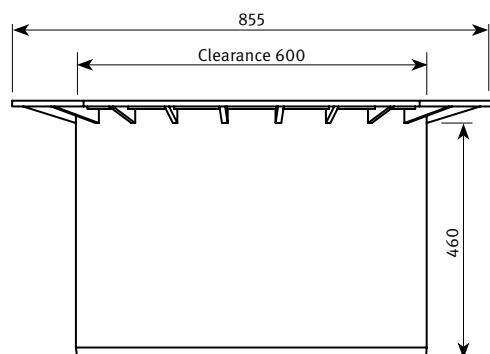



Wastewater treatment solutions

For more information about our wastewater treatment solutions, ask for our catalogue.

Prices:

A price list with our export conditions is available on request.

Warranty clause:

The warranty mentioned in this brochure only refers to the tank in question and not to the accessories. Within the warranty period we grant free replacement of the material. Further benefits are excluded. Pre-condition for warranty benefits are proper handling, assembly and installation according to the mounting guidelines.

N.B. Protect tanks from frost when installed above ground! In case of groundwater installation, please contact us for further information prior to purchase!

For all indications of measurements in this brochure we reserve a tolerance of +/- 3%. The usage volume of the tanks may be up to 10% lower than the tank Volume, depending on the connecting option.

Technical modifications and further development of the various products are subject to change. Errors excepted.

For all our offers and conclusions of contract, only our General Terms and Conditions of Business dated 01/03/2010 shall apply, which we will send to you on request.

Your local distributor:

GreenScape Ltd.

For Landscape & Geosynthetic Engineering

Contact Details:

Malik Mahmood Ring Road, Opposite to German Village
Sulaymaniyah
Kurdistan Region
Iraq

Tel: +964 (0) 53 3195567
Mob: +964 (0) 770 123 3588
Mob: +964 (0) 770 191 6556
Mob: +964 (0) 750 335 0735
Email: info@greenscape-ltd.com
Home Page: www.greenscape-ltd.com



Photo copyright: Fotolia.com: © mediagram (page 1)
© Alexandr_Ozerov (page 3)

Otto Graf GmbH
Kunststoffzeugnisse
Carl-Zeiss-Straße 2-6
79331 Teningen, Germany

Phone: +49(0)76 41/5 89-0
Fax: +49(0)76 41/5 89-50
mail@graf.info
www.graf-water.com

Graf UK Ltd
Target House
Thorpe Way Industrial
Estate
Banbury

Oxfordshire
OX16 4SP
Phone: +44 (0)1608 661500
info@grafuk.co.uk
www.grafuk.co.uk

© Otto Graf GmbH, Teningen, Germany
Reproduction – even in extracts –
only with written authorisation
Item no. 950398/EN