

**201008P HYDROFLOOR MICRO 04 GU4**

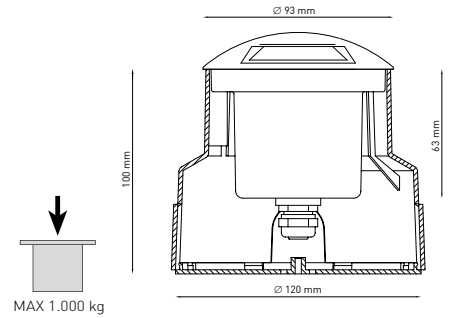

- **High corrosion resistance die-cast aluminium body**
- Polyester painting with phosphocromating pre-finish
- **Die-cast aluminium cap painted**
- Clear (or frosted) tempered glass
- Stainless steel screws
- MR11 20W max GU4 12V
- Silicone rubber gasket
- **Max static weight resistance 1000 Kg**
- Protection against impact IK09 (10 joule)
- Pg 9 cable gland
- **1 mt cable pre-wired**



**20 WATT MAX**

**MR11 - BASE GU4**

**12 VOLTS**

**IP67 - CE**  

**0,6 KG UNIT GROSS WEIGHT**

**LIGHT BEAM OPTIONS**

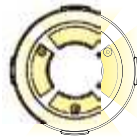

**BULB FEATURES**



MR11 - BASE GU4

**LIGHT COLOURS**

**AVAILABLE COLOURS**

 **TEXTURE**

