

201015P HYDROFLOOR MINI SQUARE GU5.3

- **High corrosion resistance die-cast aluminium body**
- Polyester painting with phosphocromating pre-finish
- **Stainless steel frame AISI 304**
- Clear (or frosted) tempered glass
- Stainless steel screws
- MR16 35W max GU5,3 12V
- Silicone rubber gasket
- **Max static weight resistance 5000 Kg**
- Protection against impact IK09 (10 joule)
- M20 cable gland
- **Polypropilene housing for recess included**

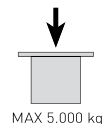
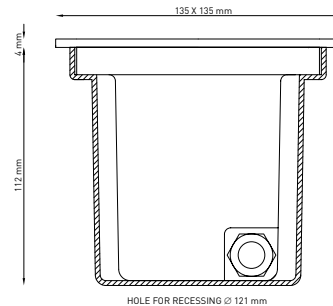
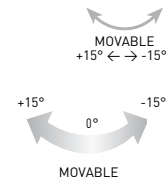

35 WATT MAX

MR16 - BASE GU5,3

12 VOLTS CONVENTIONAL

IP67 - CE  

1,2 KG UNIT GROSS WEIGHT

LIGHT BEAM OPTIONS

SEE BULB
FEATURES

BULB FEATURES



MR16 - BASE GU5,3

LIGHT COLOURS

SEE BULB
FEATURES

AVAILABLE COLOURS

 **STAINLESS STEEL**